



# Submittal Package

Project: \_\_\_\_\_

Location: \_\_\_\_\_

Architect: \_\_\_\_\_

General Contractor: \_\_\_\_\_

Applicator: \_\_\_\_\_

### Submittal Info

DDARS Notched     DDARS Speedcoat     Coatings  
 DTS Heritage     DDS Direct     FRS Stucco  
 DDARS XPS NOTCHED ci     DDARS XPS Speed Coat ci  
 FRS Stucco XPS ci     Weather Barrier

System Data  
 Product Data  
 Specification  
 Details  
 Sample Warranty

Greenmaker Industries / Decoplast is a manufacturer of EIFS Paints, Primers, Textured Finishes, Venetian Plasters, and Adhesives & Basecoats. With over 30 years in the Coatings Industry Decoplast products have been applied on over a quarter billion square feet of wall surfaces throughout; North America, South America, Europe, Asia, and the Caribbean.

- Over 30 Years in the Coatings Industry
- No Product Failures
- 5 -20 Year Labor & Material Warranties
- Over 250 Million Square Feet Installed
- AIA Accredited Provider # 40107627



697 Oakwood Avenue, West Hartford, CT 06110  
 voice: 860.761.2830 fax: 860.761.2831  
 www.decoplast.com



Find us in

building specs done right

# decoplast

**Your Source for Exterior Insulation & Finish Systems**

## Welcome to Decoplast!

For over 30 years, Decoplast Systems have been used all over the world carrying out the beauty, elegance and sophistication intended by design. Shopping Centers, Single Family Homes, Assisted Care Living Developments, Franchises, National Chains, Restaurants, Office Buildings, Hotels, Sports Complexes and Museums are just a few of the examples.

Our mission has always been to supply the EIFS / Stucco industry with products of superior quality. This is done by incorporating the latest technology along with constant monitoring, testing and refining of our entire product line. In addition to product quality, Decoplast believes in supplying Architects, Developers, Contractors, Homeowners and all valued customers with unprecedented quality in service, while maintaining competitive pricing.

Today, Decoplast is focused on our natural environment. Our most recent commitment is producing materials used in "Green Building" design. A "Green Building" minimizes a structure's environmental impact, reduces operation costs and enhances occupant comfort and well-being. We truly recognize this importance and are dedicated to making a significant contribution.

Please visit [www.DECOPLAST.com](http://www.DECOPLAST.com) We welcome any inquires that you may have.



697 Oakwood Avenue, West Hartford, CT 06110  
voice: 860.761.2830 fax: 860.761.2831  
[www.decoplast.com](http://www.decoplast.com)



## QUALIFICATION STATEMENT

Date:

Submitted To:

Project:

Decoplast is pleased to provide the following qualification statement for your review.

With industry building science expertise, and provision to offer superior products, warranty protection, service, support and design, Greenmaker Industries / Decoplast provides a single source for all your EIFS, Stucco, Masonry Construction and Coating needs.

We offer a full line of products that meet today's energy, performance and design requirements.

From building envelope design to sustainable maintenance and restoration, Decoplast provides a smarter alternative.

- *Over 30 Years in the Coatings Industry*
- *Zero product failure to date*
- *10 – 20 Year Labor and Material Warranties*
- *Over 250 million SF of product sold worldwide*
- *Miami Dade Code Compliant (NOA # 17-1227.12)*
- *FL Product Approval (FL16250-R2)*
- *AIA Provider # 40107627*
- *Texas Department of Insurance EC-79*
- *ICC ESR- 3428*
- *NFPA-285 Compliant UL File # R-38721*
- *NFPA-268 Compliant (SWRI # 21604.01.209)*
- *ASTM-E119 Compliant (reference UL Labs Project # 4787376813)*



## ORGINIZATION

**Greenmaker Industries / Decoplast** is a manufacturer of EIFS Paints, Primers, Textured Finishes, Venetian Plasters and Adhesives & Basecoats. Decoplast products have been applied on over a quarter-billion square feet of wall surfaces throughout North America, South America, Europe, Asia, and the Caribbean.

## KEY INDIVIDUALS

- CEO: Sarah Beatty
- President: John C. Di Stefano
- National Sales Manager: Mike Jalbert
- Mid-Atlantic, Ohio & North West New York: John MacLuckie
- New York, Long Island & 5 Boroughs: Mark Gassner
- Southeast, Northwest FL & Panhandle: Randall Cowart
- Florida: Brian Jordan
- Texas, Louisiana, Oklahoma & Arkansas: Araceli DeLeon
- Technical Service: Bobby Khan
- Customer Service and Inside Sales: Luisa DosSantos
- Head of Production and Product Development: Athos Perin
- Architectural Sales Support Mid Atlantic: Debra Bury
- Architectural Sales Support Northeast: Dominique Cipriani

## COMPANY SPECIALTIES

- EIFS Exterior Insulation and Finish System
- Venetian Plaster
- Paints and Architectural Specialty Coatings
- Design Build Planning
- Jobsite Inspections

## MANUFACTURING LOCATIONS

- West Hartford, CT
- Mableton, GA
- Ispica RG, Italy
- Castelfranco Veneto, Italy

## INDUSTRY AFFILIATIONS

- AWCI Association of Walls and Ceilings - 3rd Party Certified for EIFS
- Northwest Walls and Ceilings
- FAWCI Florida Walls and Ceilings
- PDCA Painting and Decorating Association
- Texas Lath & Plater Association



## PERFORMANCE

With over a quarter-billion square feet of products sold worldwide and over 30 years in the coatings industry, Decoplast products have never had a product failure. With our stringent and renowned quality control procedures, from manufacturing to installation, Decoplast is one of the only products never named in a class action lawsuit for product failure.

## WARRANTY

Decoplast is proud to offer the most aggressive and complete material and labor warranties in the industry. Decoplast has labor and material warranties that range from 5-20 years for both labor and material. We at Decoplast stand behind our product. With our Project Inspection Program, Decoplast requires that our systems are installed by a registered Decoplast applicator to insure that our products may last many years beyond the life of the warranty.

## SHORT LIST OF PROJECTS COMPLETED

### HOSPITALITY

- The Wynn Hotel and Casino - Las Vegas, NV (completed in 2007 /250,000 SF)
- Excalibur Hotel and Casino - Las Vegas, NV (completed in 2006)
- Sonesta Hotels and Condos - Sanibel Island, FL
- Hard Rock Hotel and Casino - Fort Lauderdale, FL (completed in 2004)
- Hilton Hotel Properties
  - Home 2 Suites (Gulfport, MS)
  - Home 2 Suites (Pensacola, FL)
  - Hampton Inn (Gulf Shores, AL)
  - Hampton Inn (Milwaukie, WI)
  - Hampton Inn (Gulfport, MS)
  - Hampton Inn (Bartonsville, PA)
  - Hampton Inn (Panama City, FL)
  - TRU Hotel (McDonough, GA)
- Walt Disney World – Orlando, FL (completed in 2001)
- Flamingo Hotel Casino - Las Vegas, NV (completed in 2002)
- Holiday Inn Express
- Hotel RIU Plaza - NY, NY
- Choice Hotels Group
- Marriott Hotel Group
  - Fairfield Inn (Plainville, CT)
  - Fairfield Inn (181 3rd Ave Brooklyn, NY)
  - Town Place Suites (Shalimar, FL)
  - Fairfield Inn (Atmor, AL)
  - Fairfield Inn (Saraland, AL)
  - Fairfield Inn (Meridian, MS)
  - Fairfield Inn (Gulfport, MS)



**SHORT LIST OF PROJECTS COMPLETED CONTINUED**

**COMMERCIAL / RETAIL / MIXED-USE—RESIDENTIAL / RESTAURANT**

- Conde Nast Building - Times Square, NY, NY (completed in 1997)
- Tiffany Company Store - Nationally Specified (85 Locations completed to date)
- Empire State Building (completed in 1984)
- Arizona Beverage Company Headquarters (completed in 2000)
- CVS Pharmacy - Nationally Specified (Over 250 stores completed to date)
- Old Navy
- Wendy's
- Anthropology Stores (Nationally Specified)
- Pottery Barn Stores (Nationally Specified)
- Altar'd State Retail Stores (Nationally Specified)
- McDonald's (Over 200 stores completed to date)
- Burger King (Over 125 stores completed to date)
- LA Fitness
- Dunkin Donuts
- Dunkin Donuts Stadium Hartford CT
- Shops @ Corpus - Corpus Christie, Texas
- Taco Bell
- O'Reilly Auto Parts
- Advance Auto Parts
- Auto Zone
- TJ Maxx
- Verizon Wireless
- Publix
- Petco
- Villagio at Yarrow Bay, Washington State (500,000 SF)

**GOVERNMENTAL / CIVIC / EDUCATIONAL**

- Naval Air Station Patuxent River, MD
- UNLV Library and Dorms – Las Vegas, NV (completed in 1998)
- Yankee Stadium (completed in 2008)
- City Field (completed in 2008)
- CIA Building – Langley, VA (completed in 2005)
- American Consulate – Rome, Italy (completed 1985)
- Yale University - New Haven, CT (completed in 1995)
- MOMA Museum of Modern Art (1992 and expansion in 2003)
- Arthur Ash Tennis Stadium -Flushing Meadows, NY

---

**Greenmaker Industries**  
**697 Oakwood Ave**  
**West Hartford, CT 06110**

**Greenmaker Industries**  
**5841 Jacaranda Dr. SE**  
**Mableton, GA 30126**

[www.decoplast.com](http://www.decoplast.com)

**860-761-2830**

## CSI SECTION 07 24 00 – Insulation & Finish System (EIFS) - Class PB 07 25 19 - Water-Drainage Exterior Insulation and Finish System

### SYSTEM OVERVIEW

The Decoplast DTS Heritage (Light Commercial/Residential) System is a Class PB EIFS distinguished by installation with drainage.

It features flat expanded polystyrene (EPS) insulation board mechanically fastened over Decoplast WT Wrap or a means of drainage (DrainBoard or Drainage Mat) over code approved water resistive barrier.

The WT Wrap a water-resistive barrier while its grooved pattern provides drainage.

The Decoplast DTS Heritage is qualified for combustibile construction only. Its use is generally limited to walls with design-negative windloads not over 29 pounds per square foot. Contact Decoplast Technical Department for higher loads.

- Coordination and sequencing:
  - Flashing membrane must be installed in rough openings before windows, doors, etc.
  - Flashings that are counter-flashed by EIFS must be installed before the EIFS. Such flashings include “kick-outs,” deck flashings, etc.
- All penetrations and terminations of the system must be made weather-tight, typically by sealants and/or flashings.
- Weeps of vented track and flashings must not be blocked.

### PART 1 - GENERAL

#### 1.1 SECTION INCLUDES

- A. Manufacturer’s requirements for the proper design, use, and installation of an Exterior Insulation and Finish System.

#### 1.2 RELATED SECTIONS

- A. Section 03 30 00 - Cast-in-Place Concrete
- B. Section 04 20 00 - Unit Masonry
- C. Section 06 16 00 - Sheathing
- D. Section 07 62 00 - Sheet Metal Flashing and Trim
- E. Section 07 90 00 - Joint Protection
- F. Section 08 50 00 - Windows
- G. Section 09 21 16 - Gypsum Board Assemblies

#### 1.3 REFERENCES

- A. ASTM B117 Test Method for Salt Spray (Fog) Testing
- B. ASTM C203 Standard Test Method for Breaking Load and Flexural Properties of Block-Type Thermal Insulation
- C. ASTM C1135 Test Method for Determining Tensile Adhesion Properties of Structural Sealants
- D. ASTM D968 Standard Test Methods for Abrasion Resistance of Organic Coatings by Falling Abrasive
- E. ASTM D1037 Standard Test Methods for Evaluating Properties of Wood-Base Fiber and Particle Panel Materials
- F. ASTM D2247 Practice for Testing Water Resistance of Coatings in 100 Percent Relative Humidity
- G. ASTM D2294 Standard Test Method for Creep Properties of Adhesives in Shear by Tension

- Loading (Metal-to-Metal).
- H. ASTM D2794 Standard Test Method for Resistance of Organic Coatings to the Effects of Rapid Deformation (Impact)
  - I. ASTM D3273 Standard Test Method for Resistance to Growth of Mold on the Surface of Interior Coatings in an Environmental Chamber
  - J. ASTM E84 Test Method for Surface Burning Characteristics of Building Materials.
  - K. ASTM E108 Standard Test Methods for Fire Tests of Roof Coverings
  - L. ASTM E119 Standard Test Method for Fire Tests of Building Construction and Materials.
  - M. ASTM E330 Test Method for Structural Performance by Uniform Static Air Pressure Difference.
  - N. ASTM E331 Test Method for Water Penetration by Uniform Static Air Pressure Difference.
  - O. ASTM E695 Method for Measuring Relative Resistance to Impact Loading.
  - P. ASTM E2134 Standard Test Method for Evaluating the Tensile-Adhesion Performance of an Exterior Insulation and Finish System (EIFS)
  - Q. ASTM E2273 Standard Test Method for Determining the Drainage Efficiency of Exterior Insulation and Finish Systems (EIFS) Clad Wall Assemblies
  - R. ASTM E2430 Standard Specification For Expanded Polystyrene (“EPS”) Thermal Insulation Boards For Use In Exterior Insulation and Finish Systems (“EIFS”)
  - S. ASTM E2485 Standard Test Method for Freeze/Thaw Resistance of Exterior Insulation and Finish Systems (EIFS) and Water Resistive Barrier Coatings
  - T. ASTM E2486 Standard Test Method for Impact Resistance of Class PB and PI Exterior Insulation and Finish Systems (EIFS)
  - U. ASTM G155/  
G153 Accelerated Weathering for Exposure of Nonmetallic Materials.

#### 1.4 ASSEMBLY DESCRIPTION

- A. Decoplast DTS Heritage: An Exterior Insulation and Finish System (EIFS) consisting of, Expanded Polystyrene Insulation (EPS) Board, Mechanical Fasteners, Base Coat with embedded Reinforcing Fabric Mesh, Primer (Optional), and Finish Coat. This system is installed over a means of drainage and a code compliant water resistive barrier.
- B. Functional Criteria:
  - 1. General:
    - a. Insulation Board: At system termination, completely encapsulate insulation board edges by mesh reinforced base coat, substrate or drainage track (limited to terminations at foundation). The use of and maximum thickness of insulation board shall be in accordance with applicable building codes and EIFS manufacturer’s requirements.
    - b. Flashing: Flashing shall be continuous and watertight. Flashing shall be designed and installed to prevent water infiltration behind the cladding. Refer to Division 07 Flashing Section for specified flashing materials.
    - c. The configuration of the water resistive barrier, drainage plane and flashing and Decoplast materials, must allow for the egress of incidental moisture.
    - d. Inclined surfaces shall follow the guidelines listed below:
      - (1) Minimum slope: 6 in (152 mm) of vertical rise in 12 in (305 mm) of horizontal run.
      - (2) For sloped surfaces, run of slope shall be a maximum of 12 in (305 mm).
      - (3) Usage not meeting above criteria shall be approved in writing prior to installation.
    - e. The building interior shall be separated from the insulation board by 1/2 in (12.7 mm) of gypsum board or equivalent 15-minute thermal barrier.
  - 2. Performance Requirements
    - a. System to meet the performance and testing requirements of the International Code Council Acceptance Criteria AC 219
    - b. Shall meet the testing requirements of the Product Performance Sheet.
  - 3. Substrate Systems:



- a. Shall be engineered to withstand applicable design loads including required safety factor.
- b. Maximum deflection of substrate system under positive or negative design loads shall not exceed L/240 of span.
- c. Substrate dimensional tolerance: Flat within 1/4 in (6.4 mm) in any 4 ft (122 cm) radius.
- d. Surface irregularities: Sheathing not over 1/8 in (3 mm); masonry not over 3/16 in (4.8 mm).

**EDITOR NOTE: COORDINATE BELOW IMPACT RESISTANCE CLASSIFICATION REQUIREMENTS ACCORDING TO ASTM E2486 - STANDARD TEST METHOD FOR IMPACT RESISTANCE OF CLASS PB AND PI EXTERIOR INSULATION AND FINISH SYSTEMS (EIFS)**

4. Impact Resistance Classification:
  - a. Standard Impact Resistance, 25-49 in-lbs (2.8 – 5.6 J) Impact Range
  - b. Medium Impact Resistance, 50-89 in-lbs (5.7–10.1 J) Impact Range
  - c. High Impact Resistance, 90-150 in-lbs (10.2–17.0 J) Impact Range
  - d. Ultra High Impact Resistance, >150 in-lbs (> 17.0 J) Impact Range
5. Expansion Joints: Continuous expansion joints shall be installed at the following locations in accordance with manufacturer's recommendations:
  - a. At building expansion joints.
  - b. At substrate expansion joints.
  - c. At floor lines in wood frame construction.
  - d. Where EIFS prefabricated panels abut one another.
  - e. Where EIFS abuts other materials.
  - f. Where significant structural movement occurs, such as at
    - (1) Changes in roof line.
    - (2) Changes in building shape and/or structural system.
  - g. Where substrate changes

**EDITOR NOTE: INDICATE JOINT WIDTH ON DRAWINGS FOR MOVEMENT AND EXPANSION AND CONTRACTION CONDITIONS. CONSULT WITH SEALANT MANUFACTURER FOR JOINT DESIGN RECOMMENDATIONS AND WITH EIFS MANUFACTURER FOR COORDINATION OF EIFS MATERIALS.**

- h. Substrate movement and expansion and contraction of EIFS and adjacent materials shall be taken into account in design of expansion joints, with proper consideration given to sealant properties, installation conditions, temperature range, coefficients of expansion of materials, joint width to depth ratios, and other material factors. Minimum width of expansion joints shall be as follows:
        - (1) 1/2 in (12.7 mm) where EIFS abuts other materials.
        - (2) 3/4 in (19 mm) when prefabricated EIFS panel abuts another prefabricated EIFS panel.
        - (3) Larger width where indicated on drawings.
6. Manufacturer's Detail:
  - a. EIFS latest published information shall be followed for standard detail treatments.
  - b. Non-standard detail treatments shall be as recommended by manufacturer, approved by Project Designer and be part of the Contract Documents.
7. Building Code Conformance: EIFS shall be acceptable for use on this project under building code having jurisdiction.

## **1.5 SUBMITTALS**

- A. General: Submit Samples, Evaluation Reports, warranties and Certificates in accordance with Division 01 General Requirements Submittal Section.

## **1.6 QUALITY ASSURANCE**

- A. Qualifications:

1. All EIFS assembly materials must be manufactured or sold by a single-source manufacturer and must be purchased direct from the manufacturer or its authorized distributor.
2. Applicator:
  - a. Must have attended manufacturer's Educational Seminar.
  - b. Must possess a current manufacturer's certificate of education.
  - c. Must be experienced and competent in installation of plaster-like materials.
- B. Regulatory Requirements:
  1. Insulation Board: Shall be produced and labeled under a third party quality program as required by applicable building code.

### **1.7 DELIVERY, STORAGE, AND HANDLING**

- A. Delivery: Deliver materials in original packaging with manufacturer's identification.
- B. Storage: Store materials in a cool, dry location, out of sunlight, protected from weather and other harmful environment, and at a temperature above 40°F (4°C) and below 110°F (43°C) in accordance with manufacturer's instructions.

### **1.8 PROJECT / SITE CONDITIONS**

- A. Installation Ambient Air Temperature: Minimum of 40°F (4°C) and rising, and remain so for 24 hours thereafter.
- B. Substrate Temperature: Do not apply materials to substrates whose temperature are below 40°F (4°C) or contain frost or ice.
- C. Inclement Weather: Do not apply materials during inclement weather unless appropriate protection is employed.
- D. Sunlight Exposure: Avoid, when possible, installation of the materials in direct sunlight. Application of Acrylic Finishes in direct sunlight in hot weather may adversely affect aesthetics.
- E. Materials shall not be applied if ambient temperature exceeds 120°F (49°C) or falls below 40°F (4°C) within 24 hours of application. Protect materials from uneven and excessive evaporation during hot, dry weather.
- F. Prior to installation, the substrate shall be inspected for surface contamination, or other defects that may adversely affect the performance of the materials and shall be free of residual moisture.

### **1.9 COORDINATION AND SCHEDULING:**

- A. Coordination: Coordinate water-resistive membrane & air barrier coating materials installation with other construction operations.

### **1.10 WARRANTY**

- A. Warranty: Upon request, at completion of installation, provide manufacturer's Standard Limited Warranty.

## **PART 2 - PRODUCTS**

### **2.1 MANUFACTURERS**

- A. Manufacturer, Basis of Design: Decoplast, 697 Oakwood Ave. West Hartford, CT 06110 Contact: Architectural Sales or Technical Support (860.761.2830).
- B. Components: Obtain components from authorized distributors. No substitutions or additions of other materials are permitted without prior written permission from the EIFS manufacturer for this project.

### **2.2 MATERIALS**

**EDITOR NOTE: IF THE WATER RESISTIVE BARRIER DOES NOT PROVIDE DRAINAGE A MEANS OF DRAINAGE SUCH AS A DRAINAGE MAT OR GROOVED INSULATION BOARD MUST BE USED.**

- A. Secondary Water-Resistive Barrier
  - [1. Decoplast WT Wrap: Vapor-permeable air barrier and secondary weather-resistive barrier that provides drainage plane.

- [2. Code Compliant Water Resistive Barrier, must be used with a means of drainage.
  - [3. Decoplast Flashing Membrane: Self-sealing, Polyester faced, rubberized asphalt membrane, 30 mils (0.76 mm) thick.
- B. Drainage Plane
- [1. Three Dimensional Drainage Mat
  - [2. Grooved Insulation Board
- C. Insulation Board: In compliance with manufacturer's requirements for Standard System EIFS.
- [1. Produced and labeled under a third party quality program as required by applicable building code; and produced by a manufacturer approved by Decoplast.
  - [2. Shall conform to ASTM C578 and ASTM E2430, Type I and the Decoplast specification for Molded Expanded Polystyrene Insulation board.
  - [3. Maximum size shall be 2 ft x 4 ft (610 mm x 1219 mm).
  - [4. Thickness: 1.5 in, minimum (38 mm) after rasping.
- D. Base Coats:
- [1. Decoplast Liquid Base Coat: 100% acrylic polymer base, requiring the addition of Portland cement.
  - [2. Decoplast Premium Dry Base Coat: Copolymer based, factory blend of cement and proprietary ingredients requiring addition of water.
  - [3. Decoplast Liquid Hi Build basecoat: High Impact basecoat & adhesive. Copolymer based, blend of cement and proprietary ingredients, requires the addition of water.

**EDITOR NOTE: RETAIN BELOW STANDARD MESH FOR STANDARD SYSTEM FOR STANDARD IMPACT RESISTANCE CLASSIFICATION.**

- E. Reinforcing Mesh:
- [1. Standard Mesh: Weight 4.5 oz. per sq. yd. (153 g/sq m); coated for protection against alkali. Standard reinforcement of Decoplast EIFS, or for use with High Impact Mesh, or Ultra High Impact Mesh.
  - [2. Short Detail Mesh: Reinforcing mesh used for backwrapping and details.
  - [3. Self-Adhesive Detail Mesh: Reinforcing mesh used for complex details.

**EDITOR NOTE: RETAIN BELOW MESH REQUIREMENTS AFTER DETERMINATION OF IMPACT RESISTANCE CLASSIFICATION.**

- [4. Intermediate Impact 10 Mesh: Weight 12 oz per sq. yd. (407 g/sq m) Reinforcing mesh used with a Standard System, to achieve ASTM E2486 intermediate impact strength.
- [5. High Impact 14 Mesh: Weight 15 oz. per sq. yd. (509 g/sq m) Reinforcing mesh used with a Standard System; to achieve ASTM E2486 high impact strength.
- [6. Ultra-High Impact 20 Mesh: Weight 20 oz. per sq. yd. (678 g/sq m) Reinforcing mesh used with a Standard System; to achieve ultra-high impact strength.
- [7. Corner Mesh: Reinforcing mesh used as corner reinforcement; required when using Ultra-High Impact Mesh.

**EDITOR NOTE: RETAIN BELOW AND SPECIFY LOCATIONS TO RECEIVE EIFS WITH HIGHER THAN STANDARD IMPACT RESISTANCE CLASSIFICATION.**

Locations: \_\_\_\_\_; ASTM E2486 Impact Classification: \_\_\_\_\_

- F. Primer:
- [1. Decoplast Primer: 100% acrylic based coating to prepare surfaces for acrylic or elastomeric finishes.

**EDITOR NOTE: MODIFY BELOW TO SUIT REQUIREMENTS. CHOOSE ONE FINISH TYPE, TEXTURE, & COLOR**

- G. Finish

- [1. Decoplast Deco Sil: 100% acrylic polymer based finish, enhanced DPR acrylic finish with hydrophobic and photocatalytic properties, repels water, reflects UV rays, and reduces smog particles near the finish surface. Finish type, texture and color as selected by Project Designer
  - [2. Decoplast DPR Standard Finish: Factory blended, 100% acrylic polymer based finish, integrally colored. Finish type, texture and color as selected by Project Designer
  - [3. Decoplast Decolastic Finish: Factory blended, 100% acrylic polymer based elastomeric textured finish, integrally colored. Finish type, texture and color as selected by Project Designer
- H. Water: Clean, cool, potable water
- I. Portland Cement: ASTM C150, Type I or Type I-II.

## 2.3 RELATED MATERIALS AND ACCESSORIES

- A. Substrate Materials:
- [1. Glass mat gypsum sheathing conforming to ASTM C1177.
  - [2. Cement Fiber Sheathing conforming to ASTM C1186
  - [3. Gypsum Sheathing: Minimum 1/2 in (13 mm) thick, core-treated, weather-resistant, exterior gypsum sheathing complying with ASTM C79.
  - [4. Plywood: Minimum 7/16 in (8 mm) thick exterior grade or PS 1, Exposure 1, minimum 7/16 in thick, C veneer facing out, panels gapped 1/8 in at all edges.
  - [5. Oriented Strand Board (OSB): 7/16 in - 1/2 in Wall-16 or Wall-24, approved by the APA, TECO, or PSI/PTL. Stamped as Exposure 1 or Exterior Sheathing with a PS2 or PRP-108 rating.
  - [6. Other approved by manufacturer writing prior to the project.
- B. Flashing: Refer to Division 07 Flashing Section for flashing materials.
- C. Mechanical fasteners and washers:
- [1. Wind-lock Wind Devil 2 fasteners, non-thermal bridging polypropylene plastic plates and corrosion-resistant screws.
  - [2. Demand Products PB Washer, 2" diameter, polypropylene plastic plates with appropriate fasteners for framing.
  - [3. I TW Buildex GridMate PB, 2" diameter, polypropylene plastic plates with appropriate fasteners for framing.
  - [4. Rodenhouse Plasti-Grip or Grip-Lock Washer, 2" -3" diameter, polypropylene plastic plates with appropriate fasteners for framing.
- D. Sealant System:
- [1. Sealant for expansion joints between panelized EIFS sections shall be ultra-low modulus designed for minimum 100% elongation and minimum 50% compression and as selected by Project Designer.
  - [2. Sealant for perimeter seals around window and door frames and other wall penetrations shall be low modulus, designed for minimum 50% elongation and minimum 25% compression, and as selected by Project Designer.
  - [3. Sealants shall conform to ASTM C 920, Grade NS.
  - [4. Expansion joints between sections of EIFS shall have a minimum width of 3/4 in (19 mm).
  - [5. Perimeter seal joints shall be a minimum width of 1/2 in (12.7 mm).
  - [6. Sealant backer rod shall be closed-cell polyethylene foam.
  - [7. Apply sealant to tracks or base coat of EIFS.
  - [8. Refer to EIFS manufacturer's current bulletin for listing of sealants which have been tested and have been found to be compatible with EIFS materials.
  - [9. Color shall be as selected by Project Designer.
  - [10. Joint design, surface preparation, and sealant primer shall be based on sealant manufacturer's recommendations and project conditions.

EDITOR NOTE: PART 3 EXECUTION BELOW INVOLVES ONSITE WORK AND SHOULD INCLUDE PROVISIONS FOR INCORPORATING MATERIALS AND PRODUCTS INTO PROJECT. TYPICALLY, "CONDITIONS OF THE CONTRACT" ESTABLISH RESPONSIBILITY FOR "MEANS, METHODS, TECHNIQUES, AND SAFETY" REQUIREMENTS OF CONSTRUCTION WITH CONTRACTOR. SPECIFICATIONS SHOULD AVOID CONFLICTS WITH THIS CONTRACTUAL PRINCIPLE.

## **PART 3 - EXECUTION**

### **3.1 EXAMINATION**

- A. Verify project site conditions under provisions of Section 01 00 00.
- B. Compliance: Comply with manufacturer's instructions for installation.
- C. Substrate Examination: Examine prior to installation of EIFS assembly materials as follows:
  - 1. Substrate shall be of a type approved by manufacturer. Plywood and OSB substrates shall be gapped 1/8 in (3.2 mm) at all edges.
  - 2. Substrate shall be examined for soundness, and other harmful conditions.
  - 3. Substrate shall be free of dust, dirt, laitance, efflorescence, and other harmful contaminants.
  - 4. Substrate construction in accordance with substrate material manufacturer's specifications and applicable building codes.
  - 5. Maximum deflection of the substrate shall be limited to L/240.
- D. Sealants and Backer Rod: To be installed, where required, in accordance with the sealant manufacturer's specifications and published literature, and using the sealant manufacturer's recommended primers.
- E. Advise Contractor of discrepancies preventing proper installation of the EIFS materials. Do not proceed with the work until unsatisfactory conditions are corrected.

### **3.2 PREPARATION**

- A. Protection: Protect surrounding material surfaces and areas during installation of system.
- B. Clean surfaces thoroughly prior to installation.
- C. Prepare surfaces using the methods recommended by the manufacturer for achieving the best result for the substrate under the project conditions.

### **3.3 MIXING**

- A. Mix materials in accordance with manufacturer's instructions.

### **3.4 APPLICATION**

- A. General: Installation shall conform to this specification and manufacturer's written instructions.
- B. Drainage Accessories and Water Resistive Barrier
  - 1. Install drainage tracks (limited to terminations at foundations), back-wrap mesh, or edge-wrap mesh at system terminations.
  - 2. Flash all rough openings with Decoplast Liquid Weather Resistive Barrier or Decoplast Speed Coat Moisture Barrier (trowel applied) and embedded Decoplast Sheathing Tape or Peel and Stick Flashing Membrane
  - 3. Install water resistive barrier in accordance with manufacturer's instructions making all laps weatherboard fashion to provide continuity of water shedding.
- [C. Drainage Mat: Fastened to allow temporary placement until the Insulation Board is installed.
- D. Insulation Board
  - 1. Install Wind-lock fasteners to secure insulation board to the wall in accordance with Wind-lock Corporation instructions. For exterior grade gypsum sheathing and glass mat gypsum sheathing minimum screw penetration of framing members shall be 3/4 in (19 mm) into wood and three full threads through steel. Minimum eight (8) fasteners per 2' x 4' (610 mm x 1219 mm) piece of insulation board.

2. Install insulation board without gaps in a running bond pattern and interlocked at corners.
  3. Rasp irregularities off insulation board.
- E. Apply primer to base coat after drying. Primer may be omitted if it is not required by the manufacturer's product data sheets for the specified finish coat or otherwise specified for the project.
  - F. Finish Coat: Apply finish coat to match specified finish type, texture, and color. Do not apply finish coat to surfaces to receive sealant. Keep finish out of sealant joint gaps.

### **3.5 CLEAN-UP**

- A. Removal: Remove and legally dispose of EIFS materials from job site.
- B. Clean surfaces and work area of foreign materials resulting from material installation.

### **3.6 PROTECTION**

- A. Provide protection of installed materials from water infiltration into or behind them.
- B. Provide protection of installed materials from dust, dirt, precipitation, and freezing during installation, and continuous high humidity until fully cured and dry.
- C. Clean exposed surfaces using materials and methods recommended by the manufacturer of the material or product being cleaned. Remove and replace work that cannot be cleaned to the satisfaction of the Project Designer/Owner.

END OF SECTION

Rev. Jan 2016

*Disclaimer: This guide specification is intended for use by a qualified designer. The guide specification is not intended to be used verbatim as an actual specification without appropriate modifications for the specific use intended. The guide specification must be integrated into and coordinated with the procedures of each design firm, and the requirements of a specific project. For additional assistance, contact Decoplast Architectural Sales or Technical Support (860-761-2830).*

EIFS Strength	Method	ICC or ASTM Criteria	Results
Flexural Strength	ASTM C203	No Requirement	60.6 psi (418 kPa)
Falling Ball Impact	ASTM D1037	No Requirement	92 to over 600 in-lbs
Creep Resistance of Adhesive	ASTM D2294	No Requirement	28 days 208 psf shear stress; no creep
Gardner Impact Test	ASTM D2794	No Requirement	25 to 200 in-lbs (mesh weight)
Impact Load	ASTM E695	No Current Requirement	30 lb. Impact mass; no cracking of system
Tensile Bond Strength	ASTM E2134	Minimum 15 psi (103kPa)	26 psi (179 kPa) to insulation board

EIFS Environmental Durability	Method	ICC or ASTM Criteria	Results
Abrasion Resistance	ASTM D 968	No cracking or loss of film at 528 quarts (500 L) of sand	500 liters: no deleterious effect
Accelerated Weathering	ASTM G153 ASTM G154	No deleterious effects* at 2000 hours when viewed under 5x magnification	2000 hours: no deleterious effect 2000 hours: no deleterious effect
Drainage Efficiency	ASTM E2273	90 %	Pass
Freeze/Thaw Resistance	ASTM E 2485	No deleterious effects* at 10 cycles when viewed under 5x magnification	60 cycles: no deterioration 10 cycles: pass
Fungus Resistance	MIL STD 810B		28 days: no growth
Mildew Resistance	ASTM D 3273	No growth supported during 28-day exposure period	35 days: no growth
Moisture Resistance	ASTM D2247	No deleterious effects at 14-day exposure	Pass
Salt Fog Resistance	ASTM B117	No deleterious effects* at 300 hours	500 hours: no deterioration
Water Penetration	ASTM E 331	No water penetration beyond the plane of the base coat/EPS board interface after 15 minutes at 6.24 psf (299 Pa)	Pass
Wind-Driven Rain	F.S. TT-C-555B		24 hours: no penetration of water

*\*No deleterious effects: no cracking, checking, crazing, erosion, rusting, blistering.*

<b>Reinforcing Mesh Impact Resistance</b>	<b>Classification</b>	<b>Impact Range (in-lbs)</b>
Standard Mesh	Standard	25-49
Intermediate Impact 10 Mesh	Intermediate	50-89
High Impact 15 Mesh (Plus Standard Mesh)	High	90-150
Ultra-High Impact 20 Mesh /Standard Mesh	Ultra High	>150

*Where several tests on different materials are summarized, a range of values is shown. This summary has been prepared to provide quick but partial information on how certain combinations of Decoplast products perform during certain tests. It is not a complete description of the test procedures or of the results thereof. Copies of original test reports are available at no charge upon request. Please contact Decoplast Architectural Sales or Technical Support Department (860.761.2830) if further information is required.*



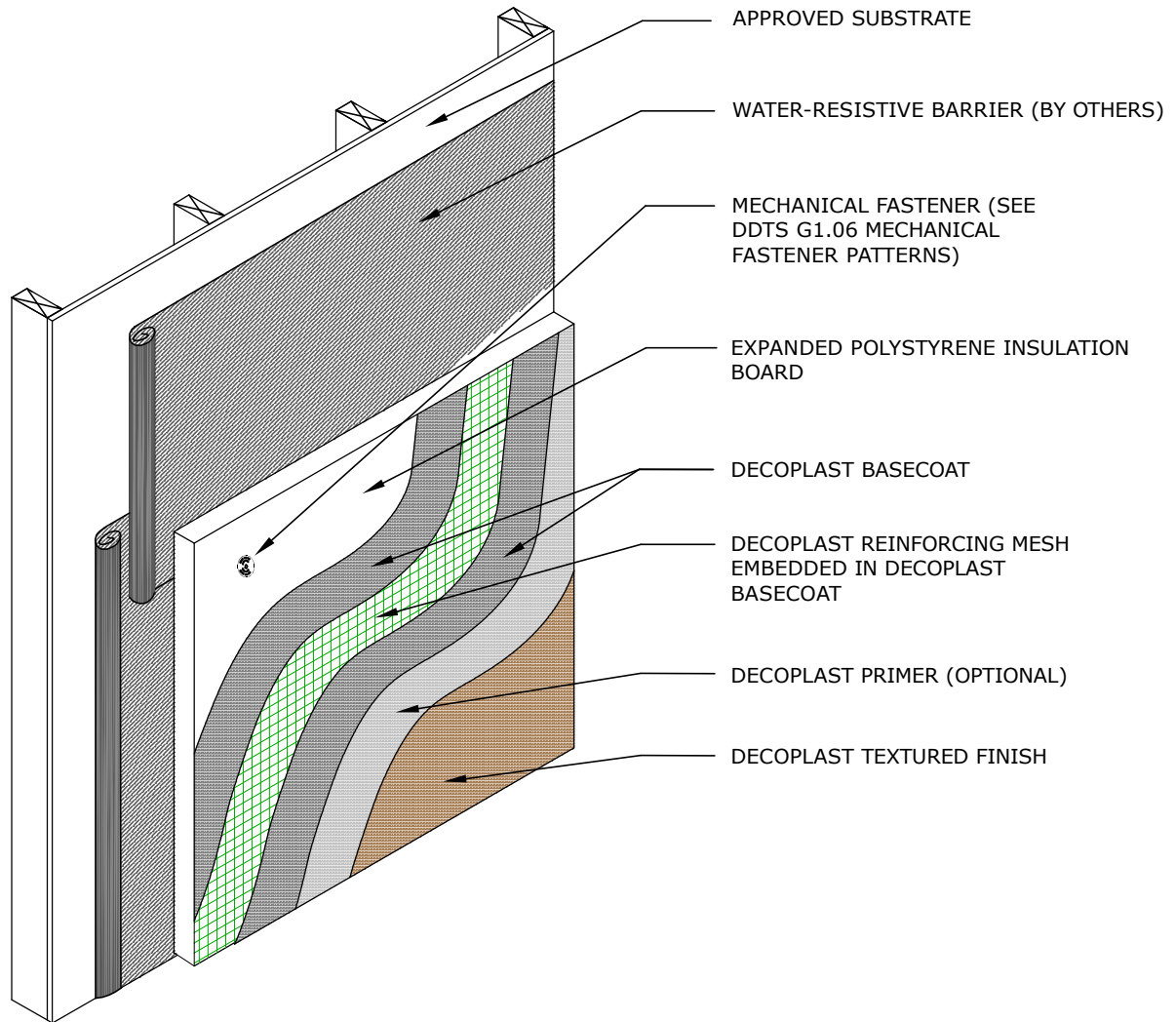

## DDTS G1.01A DTS HERITAGE STANDARD SYSTEM COMPONENTS

DECOPLAST DTS HERITAGE - 6/1/2016

### NOTES:

1. See DDTS G1.01B or C for Additional Drainage Options.
2. See DDTS G1.02 for Drainage Termination Options

Disclaimer: The design, specifications, and construction shall comply with all local building codes and standards. Decoplast installation guidelines are for general information and guidance only and Decoplast specifically disclaims any liability for the use of this design, and for design, engineering, or workmanship of any project. The assembly shall be designed to prevent condensation within the assembly. The designer and the user shall provide final drawings and specifications. Products shown other than those manufactured by Decoplast are shown for clarity of the Decoplast product only. Contact the manufacturer of such other products for installation instructions.

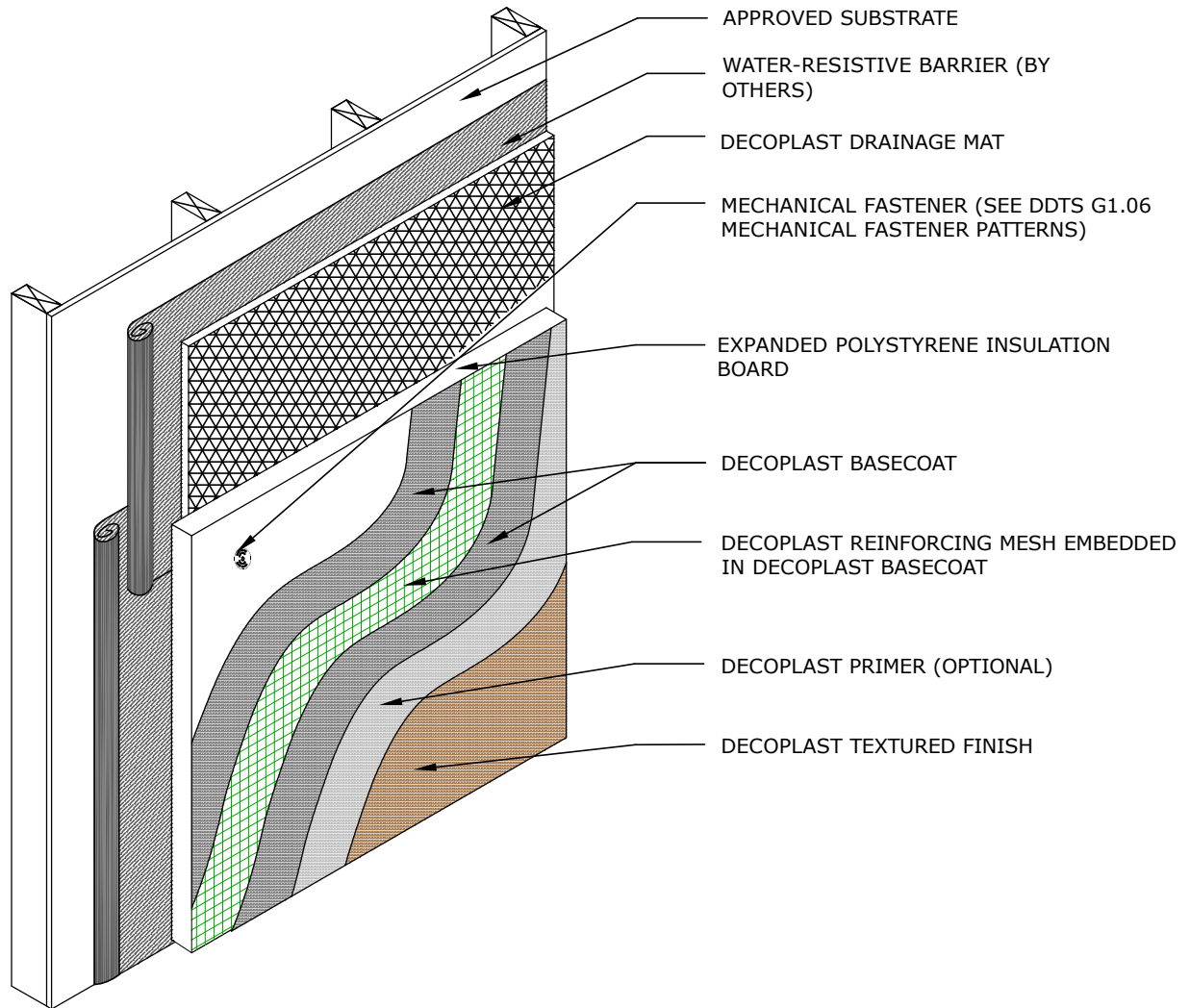

## DDTS G1.01B DTS HERITAGE STANDARD SYSTEM DRAINAGE MAT COMPONENTS

DECOPLAST DTS HERITAGE - 6/1/2016

### NOTES:

1. See DDTS G1.01A or C for Additional Drainage Options.
2. See DDTS G1.02 for Drainage Termination Options

Disclaimer: The design, specifications, and construction shall comply with all local building codes and standards. Decoplast installation guidelines are for general information and guidance only and Decoplast specifically disclaims any liability for the use of this design, and for design, engineering, or workmanship of any project. The assembly shall be designed to prevent condensation within the assembly. The designer and the user shall provide final drawings and specifications. Products shown other than those manufactured by Decoplast are shown for clarity of the Decoplast product only. Contact the manufacturer of such other products for installation instructions.

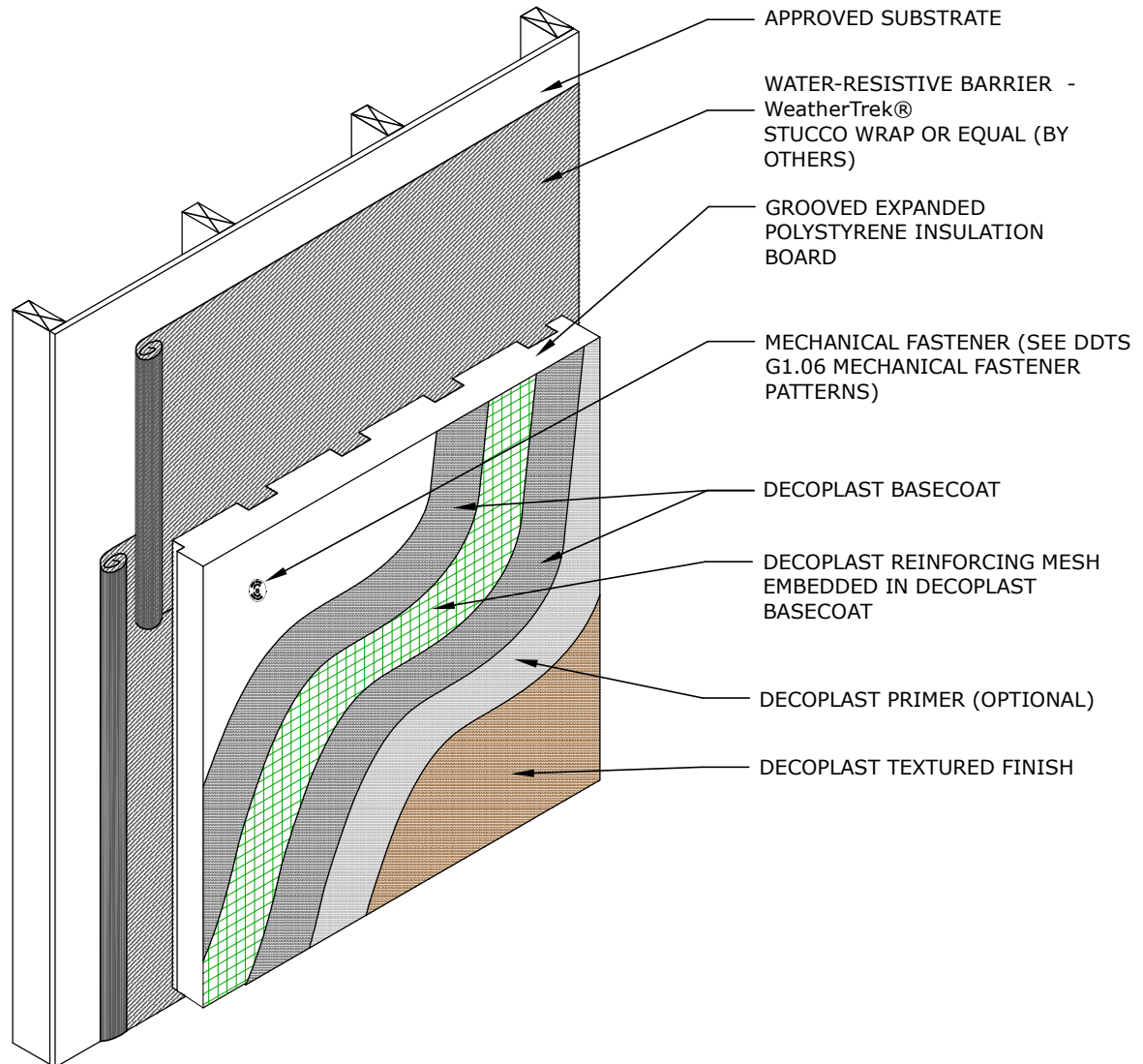

## DDTS G1.01C DTS HERITAGE STANDARD SYSTEM GROOVED EPS BOARD COMPONENTS

DECOPLAST DTS HERITAGE - 6/1/2016

### NOTES:

1. See DDTS G1.01A or B for Additional Drainage Options.
2. See DDTS G1.02 for Drainage Termination Options.

Disclaimer: The design, specifications, and construction shall comply with all local building codes and standards. Decoplast installation guidelines are for general information and guidance only and Decoplast specifically disclaims any liability for the use of this design, and for design, engineering, or workmanship of any project. The assembly shall be designed to prevent condensation within the assembly. The designer and the user shall provide final drawings and specifications. Products shown other than those manufactured by Decoplast are shown for clarity of the Decoplast product only. Contact the manufacturer of such other products for installation instructions.

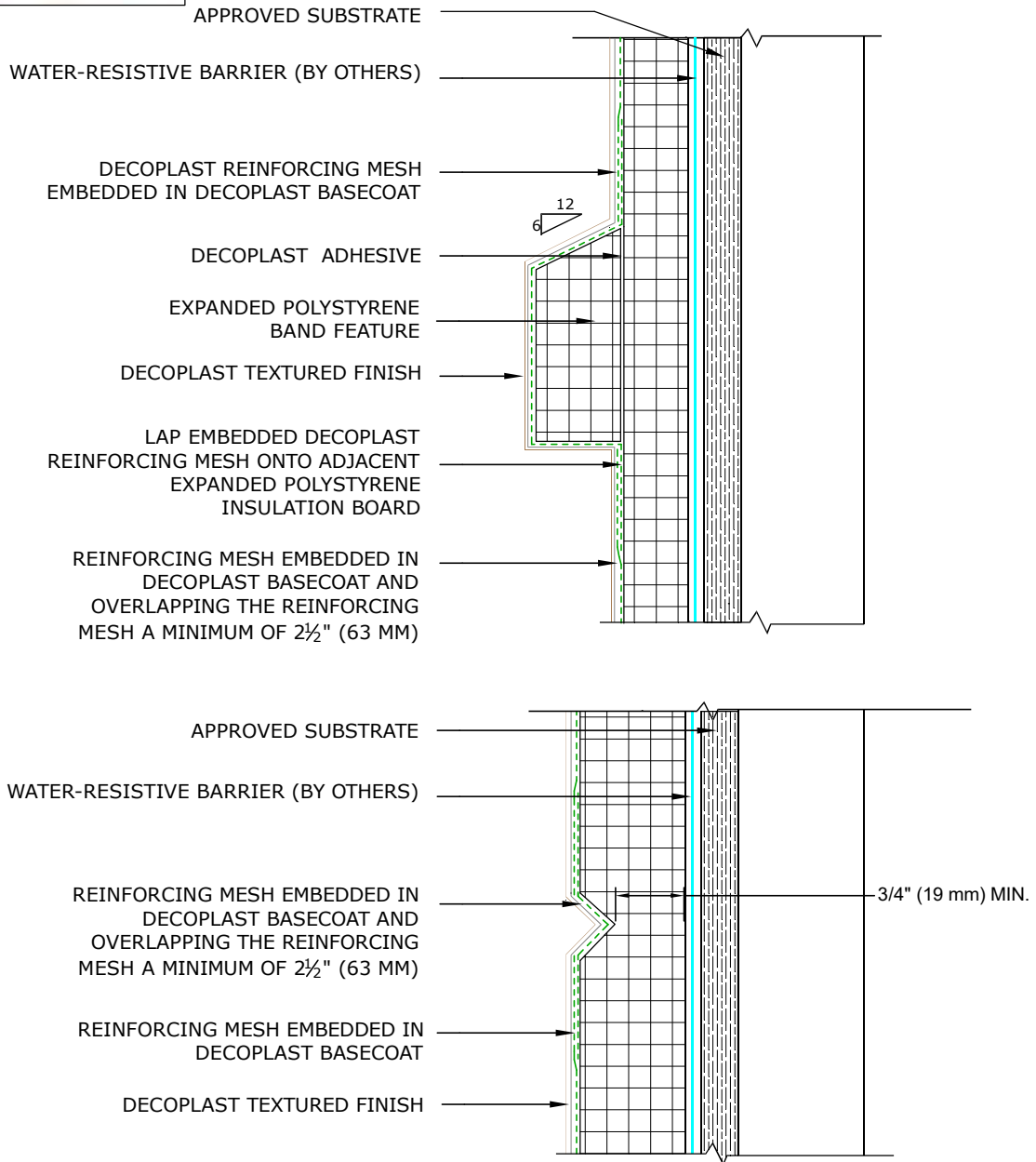

## DDTS A1.01 DTS HERITAGE AESTHETIC BAND AND REVEAL

DECOPLAST DTS HERITAGE - 6/1/2016

NOTES:

1. See DDTS G1.01 A, B or C for Drainage Options.
2. See DDTS G1.02 for Drainage Termination Options.

Disclaimer: The design, specifications, and construction shall comply with all local building codes and standards. Decoplast installation guidelines are for general information and guidance only and Decoplast specifically disclaims any liability for the use of this design, and for design, engineering, or workmanship of any project. The assembly shall be designed to prevent condensation within the assembly. The designer and the user shall provide final drawings and specifications. Products shown other than those manufactured by Decoplast are shown for clarity of the Decoplast product only. Contact the manufacturer of such other products for installation instructions.

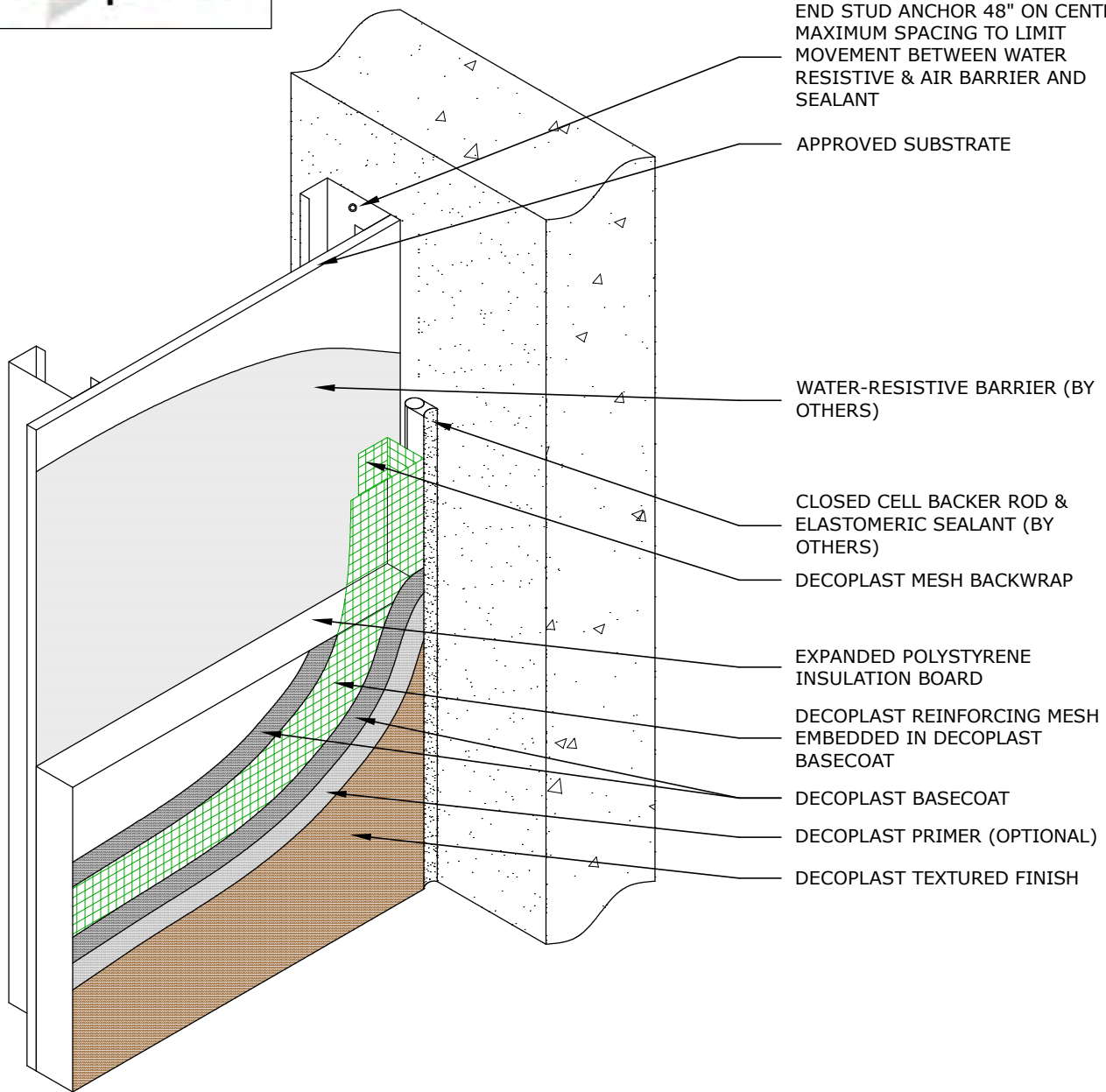

## DDTS E1.01 DTS HERITAGE INSIDE CORNER TERMINATION

DECOPLAST DTS HERITAGE - 6/1/2016

NOTES:

1. See DDTS G1.01 A, B or C for Drainage Options.
2. See DDTS G1.02 for Drainage Termination Options.

Disclaimer: The design, specifications, and construction shall comply with all local building codes and standards. Decoplast installation guidelines are for general information and guidance only and Decoplast specifically disclaims any liability for the use of this design, and for design, engineering, or workmanship of any project. The assembly shall be designed to prevent condensation within the assembly. The designer and the user shall provide final drawings and specifications. Products shown other than those manufactured by Decoplast are shown for clarity of the Decoplast product only. Contact the manufacturer of such other products for installation instructions.

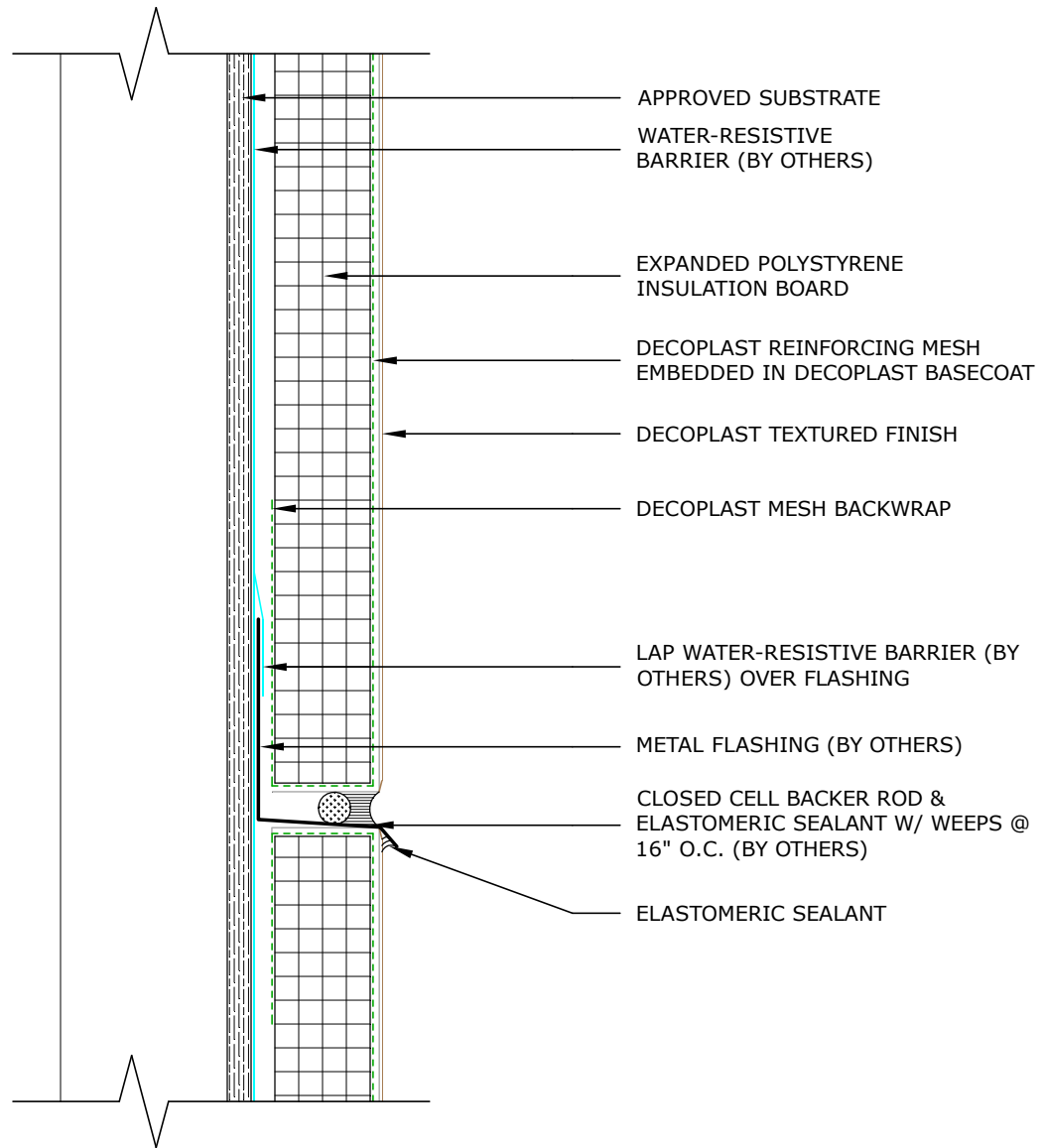

## DDTS E1.02 DTS HERITAGE THRU-SYSTEM FLASHING WITH WEEPS

DECOPLAST DTS HERITAGE - 6/1/2016

### NOTES:

1. See DDTS G1.01 A, B or C for Drainage Options.
2. See DDTS G1.02 for Drainage Termination Options.

Disclaimer: The design, specifications, and construction shall comply with all local building codes and standards. Decoplast installation guidelines are for general information and guidance only and Decoplast specifically disclaims any liability for the use of this design, and for design, engineering, or workmanship of any project. The assembly shall be designed to prevent condensation within the assembly. The designer and the user shall provide final drawings and specifications. Products shown other than those manufactured by Decoplast are shown for clarity of the Decoplast product only. Contact the manufacturer of such other products for installation instructions.

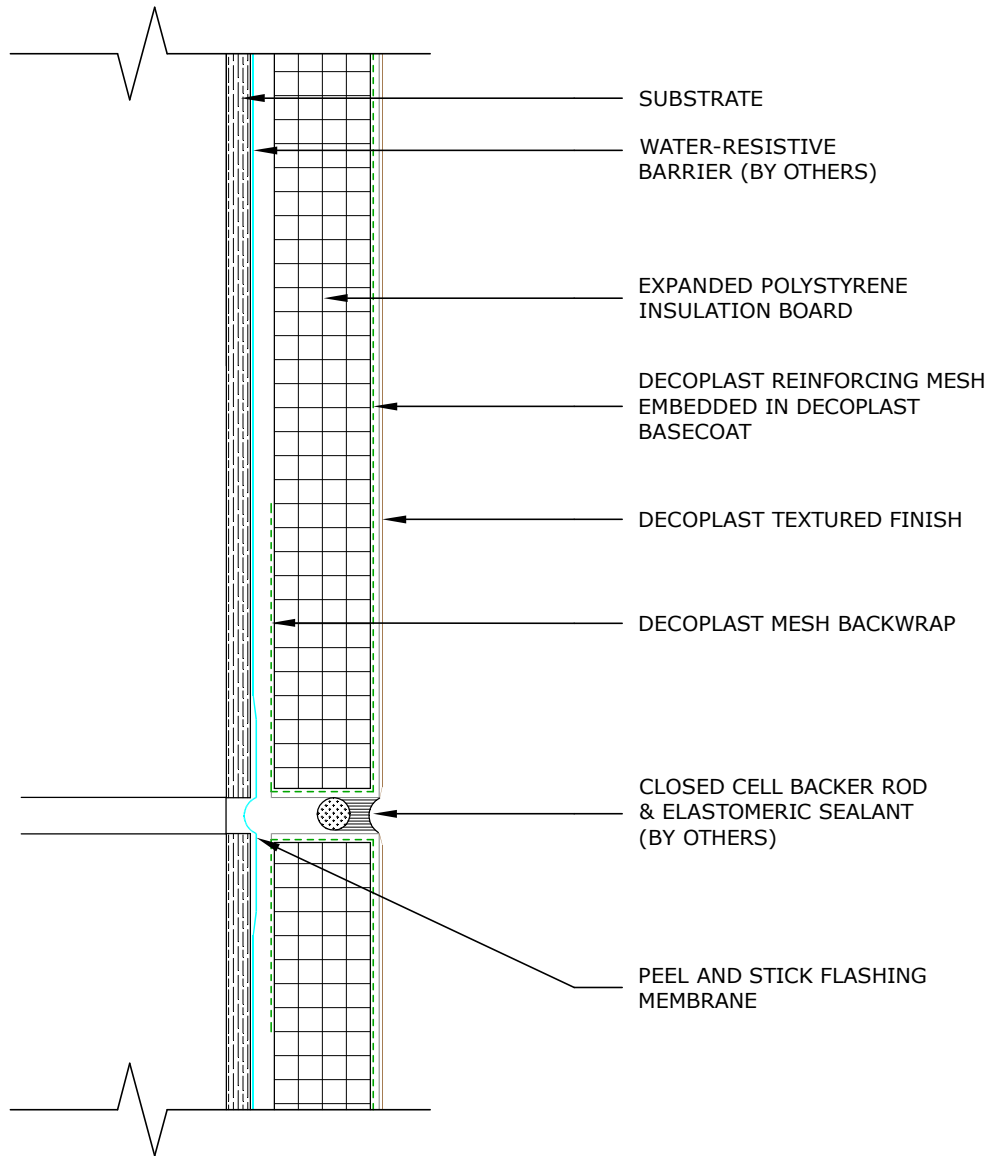

## DDTS E1.07 DTS HERITAGE HORIZONTAL EXPANSION JOINT

DECOPLAST DTS HERITAGE - 6/1/2016

### NOTES:

1. See DDTS G1.01 A, B or C for Drainage Options.
2. See DDTS G1.02 for Drainage Termination Options.

Disclaimer: The design, specifications, and construction shall comply with all local building codes and standards. Decoplast installation guidelines are for general information and guidance only and Decoplast specifically disclaims any liability for the use of this design, and for design, engineering, or workmanship of any project. The assembly shall be designed to prevent condensation within the assembly. The designer and the user shall provide final drawings and specifications. Products shown other than those manufactured by Decoplast are shown for clarity of the Decoplast product only. Contact the manufacturer of such other products for installation instructions.

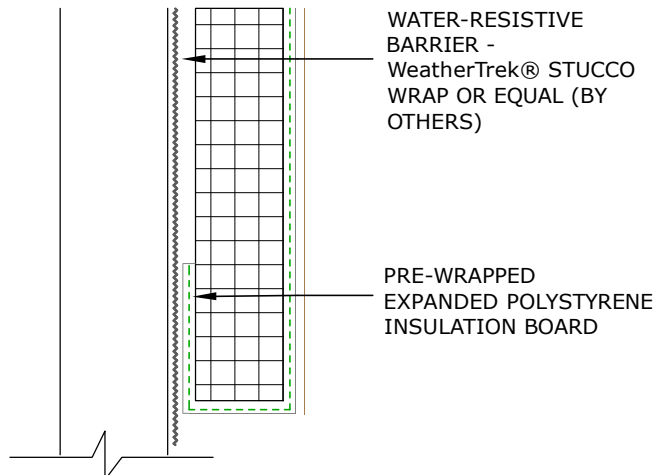
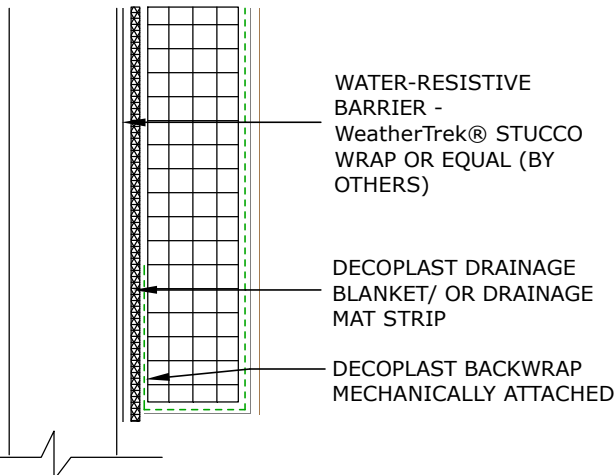
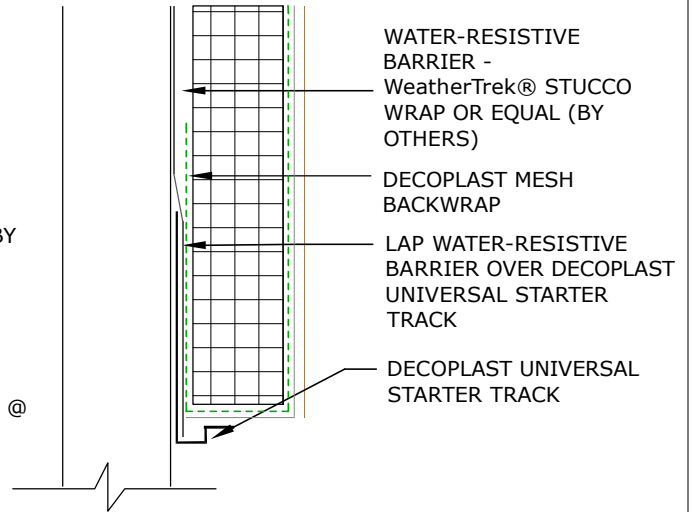
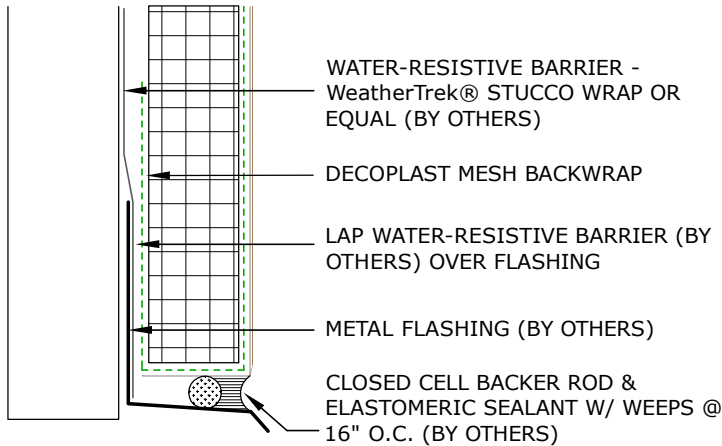

## DDTS G1.02 DTS HERITAGE DRAINAGE TERMINATION OPTIONS

DECOPLAST DTS HERITAGE - 6/1/16

- NOTES:
1. Water-Resistive barriers must be continuous over the entire project.
  2. Water-Resistive barriers must be lapped shingle wise or counter-flashed to other watertight construction or bonded watertight adjoining watertight construction.
  3. Flashing may be omitted at foundation terminations where the system and water -resistive barrier lap over the foundation. Lap shall be sufficient to prevent water intrusion.

Disclaimer: The design, specifications, and construction shall comply with all local building codes and standards. Decoplast installation guidelines are for general information and guidance only and Decoplast specifically disclaims any liability for the use of this design, and for design, engineering, or workmanship of any project. The assembly shall be designed to prevent condensation within the assembly. The designer and the user shall provide final drawings and specifications. Products shown other than those manufactured by Decoplast are shown for clarity of the Decoplast product only. Contact the manufacturer of such other products for installation instructions.



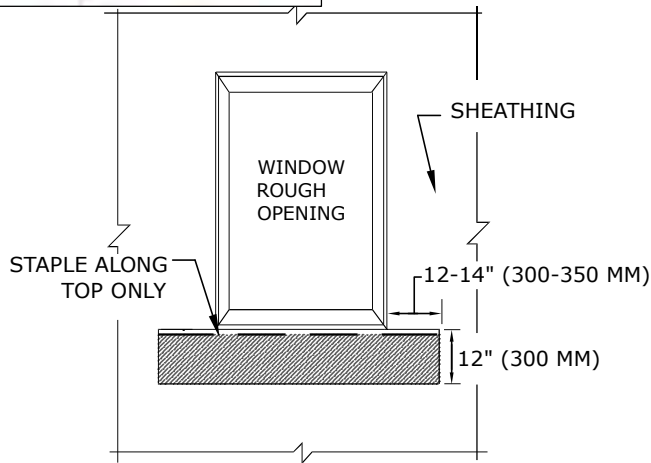

**STEP 1: WeatherTrek® (OR EQUAL) UNDER SILL**

CUT WeatherTrek® APPROXIMATE SIZE SHOWN. STAPLE INTO PLACE AT BOTTOM OF THE ROUGH OPENING. IMPORTANT! WeatherTrek® SHOULD ONLY BE STAPLED ALONG THE TOP EDGE.

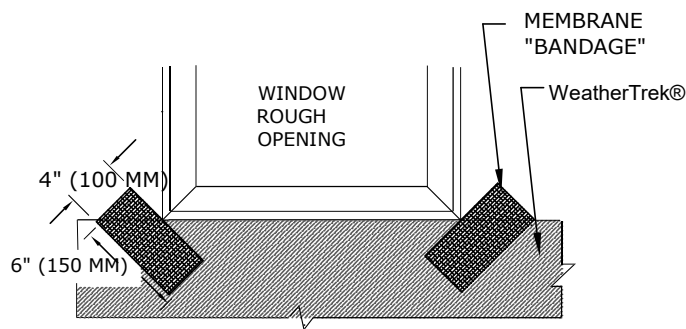

**STEP 2 : INSTALL FLASHING MEMBRANE "BANDAGES"**

PEEL PROTECTIVE BACKER FROM DECO-SHIELD AND INSTALL DIAGONALLY AT SILL CORNERS AS SHOWN. SHEATHING OR WeatherTrek® SHOULD NOT BE VISIBLE AT THE CORNERS OF THE ROUGH OPENING.

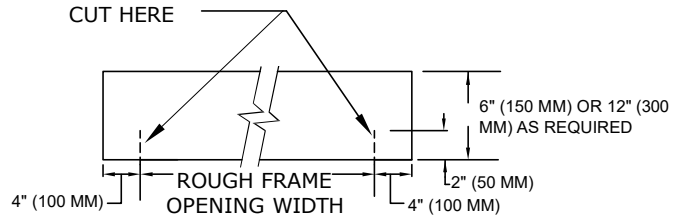

**STEP 3: CUTTING DECO-SHIELD FLASHING MEMBRANE**

CUT A PIECE OF DECO-SHIELD 8" (200 MM) LONGER THAN THE ROUGH OPENING WIDTH. MAKE 2 SMALL CUTS THROUGH THE MEMBRANE AS SHOWN.

NOTE: SELECT DECO-SHIELD WIDTH 6" (150 MM) OR 12" (300 MM) AT LEAST 2" (50 MM) WIDER THAN THICKNESS OF SUBSTRATE WALL.

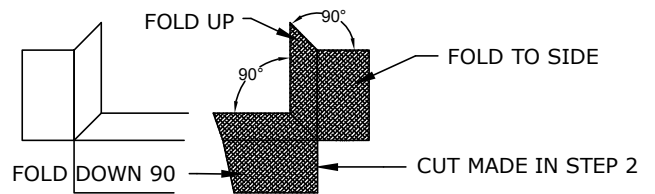

**STEP 4: FOLDING DECO-SHIELD FLASHING MEMBRANE**

FOLD MEMBRANE TO CONFORM WITH ROUGH OPENING. PEEL PROTECTIVE BACKER FROM MEMBRANE TO EXPOSE ADHESIVE

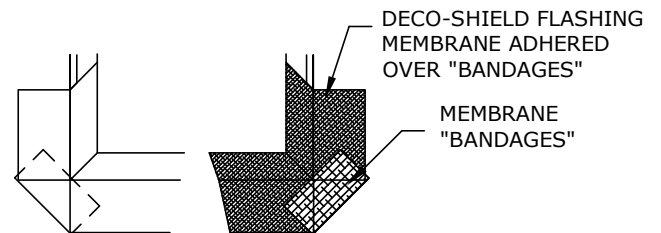

**STEP 5: INSTALLING THE DECO-SHIELD FLASHING MEMBRANE**

INSTALL THE "SELF STICKING" DECO-SHIELD AT THE ROUGH OPENING. MEMBRANE SHOULD LAP OVER THE PREVIOUSLY INSTALLED BANDAGES AND WeatherTrek®.

## DDTS G1.03A DTS HERITAGE ROUGH OPENING PROTECTION

DECOPLAST DTS HERITAGE - 6/1/2016

Disclaimer: The design, specifications, and construction shall comply with all local building codes and standards. Decoplast installation guidelines are for general information and guidance only and Decoplast specifically disclaims any liability for the use of this design, and for design, engineering, or workmanship of any project. The assembly shall be designed to prevent condensation within the assembly. The designer and the user shall provide final drawings and specifications. Products shown other than those manufactured by Decoplast are shown for clarity of the Decoplast product only. Contact the manufacturer of such other products for installation instructions.

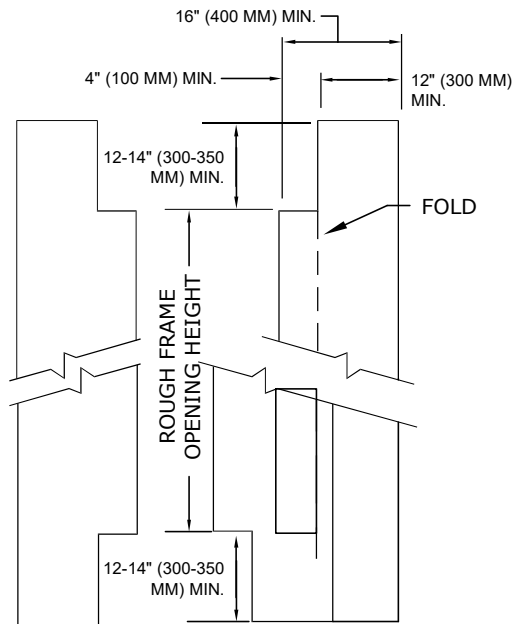

**STEP 6: CUTTING WeatherTrek® FOR JAMBS**  
 CUT THE WeatherTrek® (OR EQUAL) TO FIT  
 ROUGH OPENING JAMB

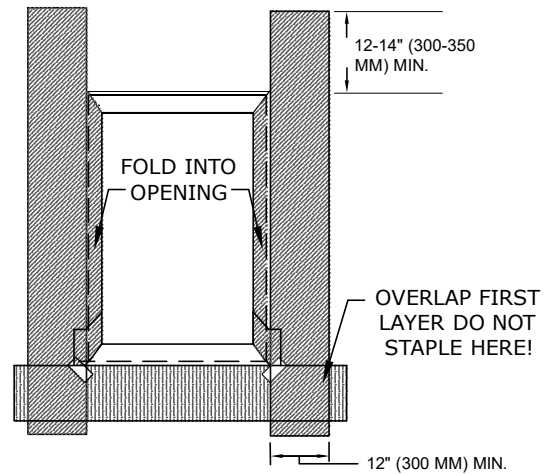

**STEP 7: INSTALLING WeatherTrek® AT JAMBS**  
 FOLD WeatherTrek® (OR EQUAL) INTO ROUGH  
 OPENING. BOTTOM LEG MUST OVERLAP FIRST  
 LAYER AS SHOWN. DO NOT STAPLE IMMEDIATELY  
 BELOW THE SILL /JAMB CORNERS.

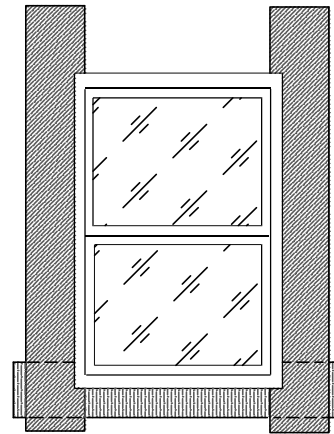

**STEP 8: INSTALLING WINDOW**  
 AFTER THE STRIPS OF WeatherTrek® HAVE BEEN  
 INSTALLED AT THE SILL AND JAMBS AS SHOWN,  
 THE WINDOW CAN BE INSTALLED

## DDTS G1.03B DTS HERITAGE ROUGH OPENING PROTECTION

DECOPLAST DTS HERITAGE - 6/1/2016

Disclaimer: The design, specifications, and construction shall comply with all local building codes and standards. Decoplast installation guidelines are for general information and guidance only and Decoplast specifically disclaims any liability for the use of this design, and for design, engineering, or workmanship of any project. The assembly shall be designed to prevent condensation within the assembly. The designer and the user shall provide final drawings and specifications. Products shown other than those manufactured by Decoplast are shown for clarity of the Decoplast product only. Contact the manufacturer of such other products for installation instructions.



# DTS HERITAGE

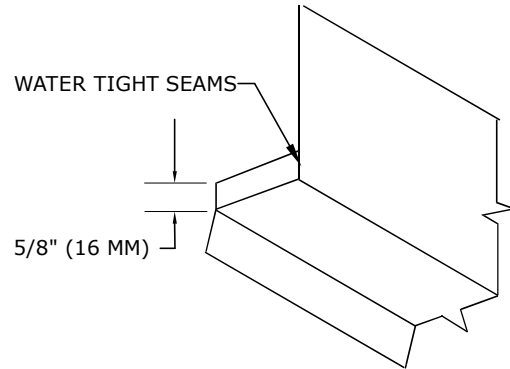
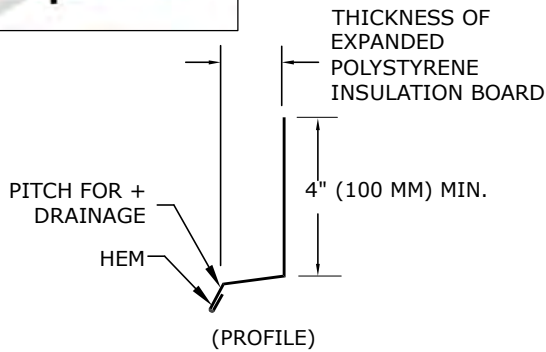

(PICTORIAL)

## STEP 9: METAL HEAD FLASHING

FLASHING SHOULD BE FABRICATED IN THE PROFILE SHOWN. LENGTH OF FLASHING IS 1" (25 MM) LONGER THAN THE WIDTH OF THE WINDOW FRAME. END DAMS SHOULD BE TURNED UPWARD 5/8" (16MM) AS SHOWN.

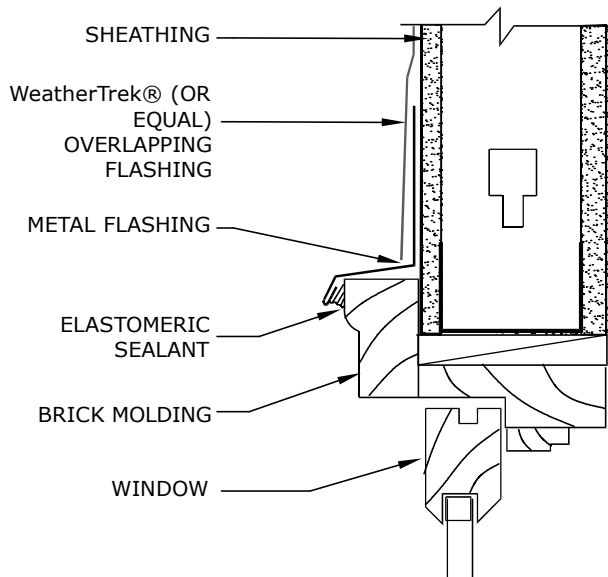

SECTION A-A  
WOOD WINDOW WITH BRICK MOULDING

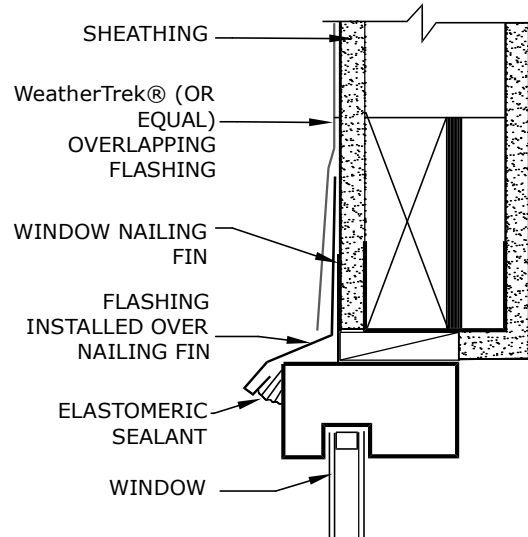

SECTION B-B  
WINDOW WITH NAILING FIN

## STEP 10: INSTALLATION OF METAL FLASHING

# DDTS G1.03C DTS HERITAGE ROUGH OPENING PROTECTION

DECOPLAST DTS HERITAGE - 6/1/2016

### NOTES:

1. The length of the flashing is dependant on the type of window used.
2. Sections A-A and B-B illustrate two types of windows.
3. Flashing should be installed as illustrated. For any unusual conditions, please contact DECOPLAST Technical Services.

Disclaimer: The design, specifications, and construction shall comply with all local building codes and standards. Decoplast installation guidelines are for general information and guidance only and Decoplast specifically disclaims any liability for the use of this design, and for design, engineering, or workmanship of any project. The assembly shall be designed to prevent condensation within the assembly. The designer and the user shall provide final drawings and specifications. Products shown other than those manufactured by Decoplast are shown for clarity of the Decoplast product only. Contact the manufacturer of such other products for installation instructions.

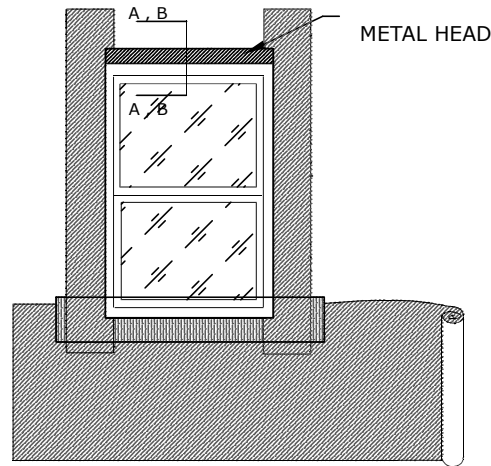

**STEP 11: INSTALLING ROLLS OF WeatherTrek® (OR EQUAL)**

INSTALL ROLLS OF WeatherTrek® HORIZONTALLY IN A SHINGLE FASHION. EACH SUCCEEDING COURSE SHOULD OVERLAP THE PREVIOUS COURSE BY 2" (50 MM) MIN.

NOTE: THE STRIPS OF WeatherTrek® PREVIOUSLY INSTALLED AT THE SILL OVERLAPS THE HORIZONTALLY INSTALLED ROLLED WeatherTrek® BELOW THE SILL FOR POSITIVE DRAINAGE.

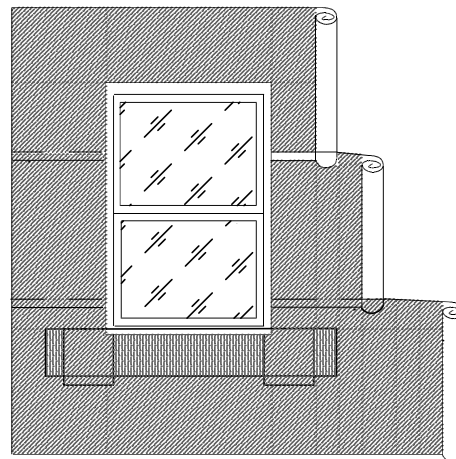

**STEP 12: INSTALLING ROLLS OF WeatherTrek® (CONTINUED)**

CONTINUE TO LAP EACH SUCCEEDING COURSE AS ILLUSTRATED FOR POSITIVE DRAINAGE.

WHERE VERTICAL SPLICES OCCUR, LAP THE WeatherTrek® A MINIMUM OF 6" (150 MM). VERTICAL SPLICES IN THE BUILDING PAPER SHOULD NOT OCCUR WITHIN 2 FEET (600 MM) OF THE WINDOW JAMBS.

NOTE THAT THE SUCCEEDING COURSES LAP OVER THE REMAINDER OF THE WeatherTrek® STRIPS AND THE METAL FLASHING AT THE HEAD.

## DDTS G1.03D DTS HERITAGE ROUGH OPENING PROTECTION

### DECOPLAST DTS HERITAGE

**NOTES:**

1. The length of the flashing is dependant on the type of window used.
2. Sections A-A and B-B illustrate two types of windows.
3. Flashing should be installed as illustrated. For any unusual conditions, please contact DECOPLAST Technical Services.

Disclaimer: The design, specifications, and construction shall comply with all local building codes and standards. Decoplast installation guidelines are for general information and guidance only and Decoplast specifically disclaims any liability for the use of this design, and for design, engineering, or workmanship of any project. The assembly shall be designed to prevent condensation within the assembly. The designer and the user shall provide final drawings and specifications. Products shown other than those manufactured by Decoplast are shown for clarity of the Decoplast product only. Contact the manufacturer of such other products for installation instructions.

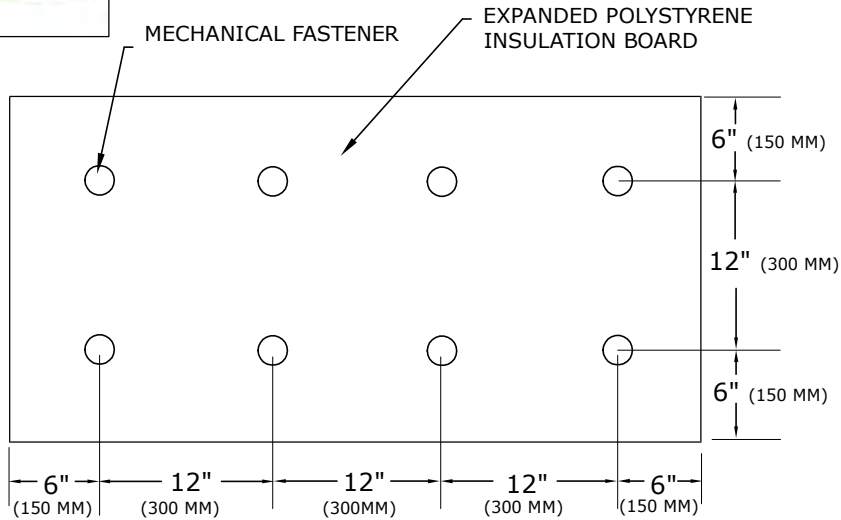

### SCREWABLE SHEATHING

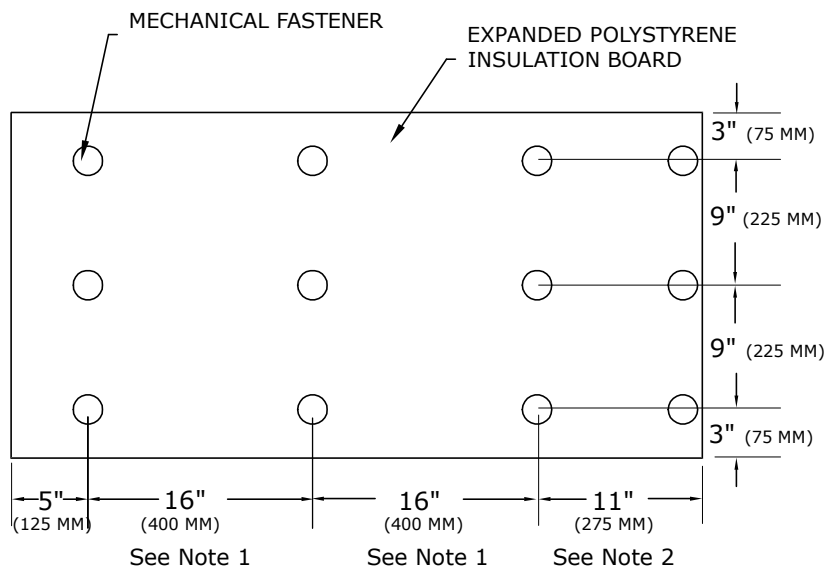

### NON-SCREWABLE SHEATHING

## DDTS G1.06 DTS HERITAGE MECHANICAL FASTENER PATTERNS

DECOPLAST DTS HERITAGE - 6/1/2016

#### NOTES:

1. Fastener spacing not to exceed 16" (400 mm) center to center.
2. Variable not to exceed 11" (275 mm) - Worst case spacing condition.

Disclaimer: The design, specifications, and construction shall comply with all local building codes and standards. Decoplast installation guidelines are for general information and guidance only and Decoplast specifically disclaims any liability for the use of this design, and for design, engineering, or workmanship of any project. The assembly shall be designed to prevent condensation within the assembly. The designer and the user shall provide final drawings and specifications. Products shown other than those manufactured by Decoplast are shown for clarity of the Decoplast product only. Contact the manufacturer of such other products for installation instructions.

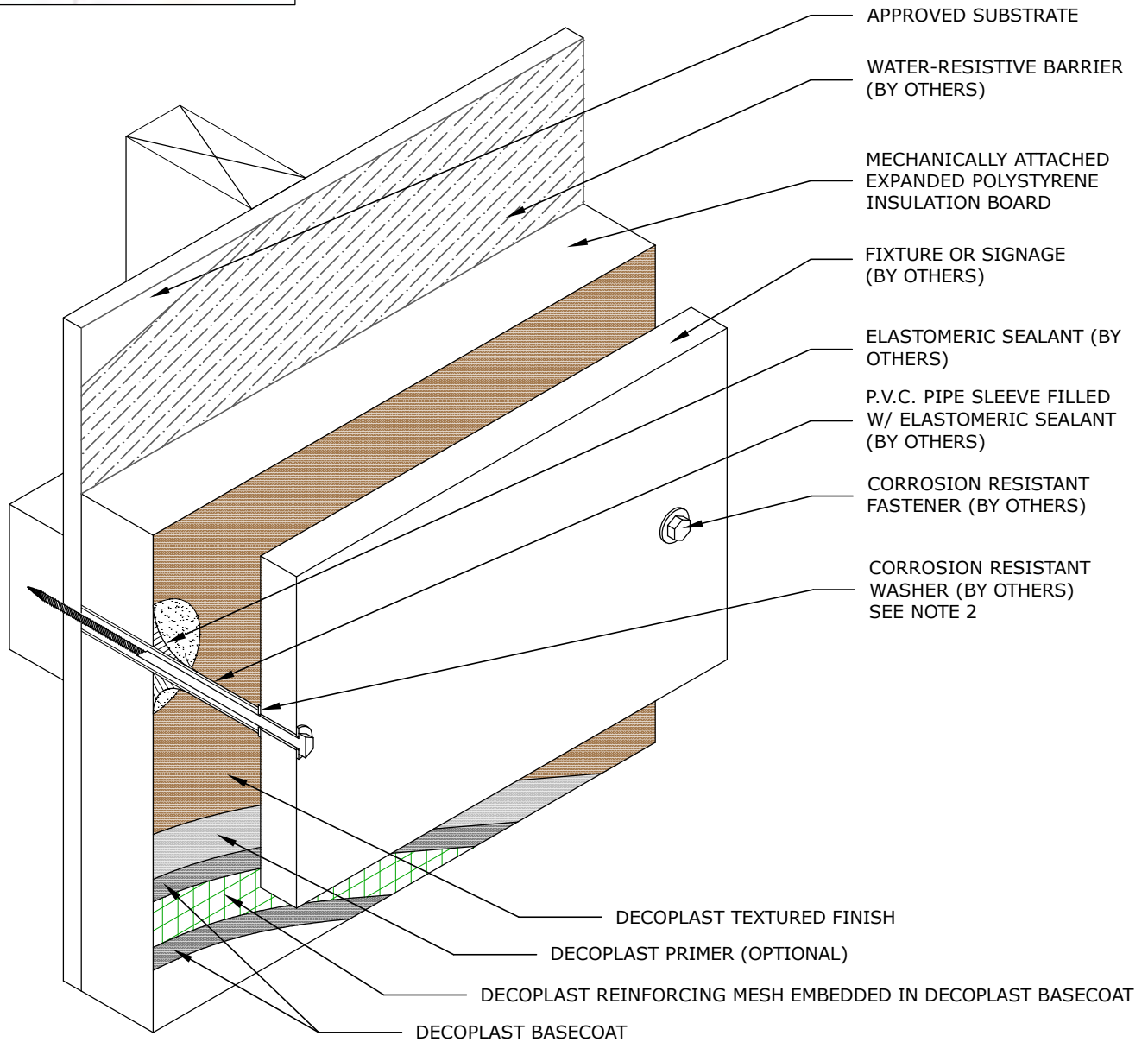

## DDTS P1.01 DTS HERITAGE FIXTURE ATTACHMENT (BY OTHERS)

DECOPLAST DTS HERITAGE

NOTE:

1. See DDTS G1.01 A, B or C for Drainage Options.
2. Fixture attachment shall be designed and installed to support all fixture loads and to prevent transfer of fixture loads to the EIFS.

Disclaimer: The design, specifications, and construction shall comply with all local building codes and standards. Decoplast installation guidelines are for general information and guidance only and Decoplast specifically disclaims any liability for the use of this design, and for design, engineering, or workmanship of any project. The assembly shall be designed to prevent condensation within the assembly. The designer and the user shall provide final drawings and specifications. Products shown other than those manufactured by Decoplast are shown for clarity of the Decoplast product only. Contact the manufacturer of such other products for installation instructions.

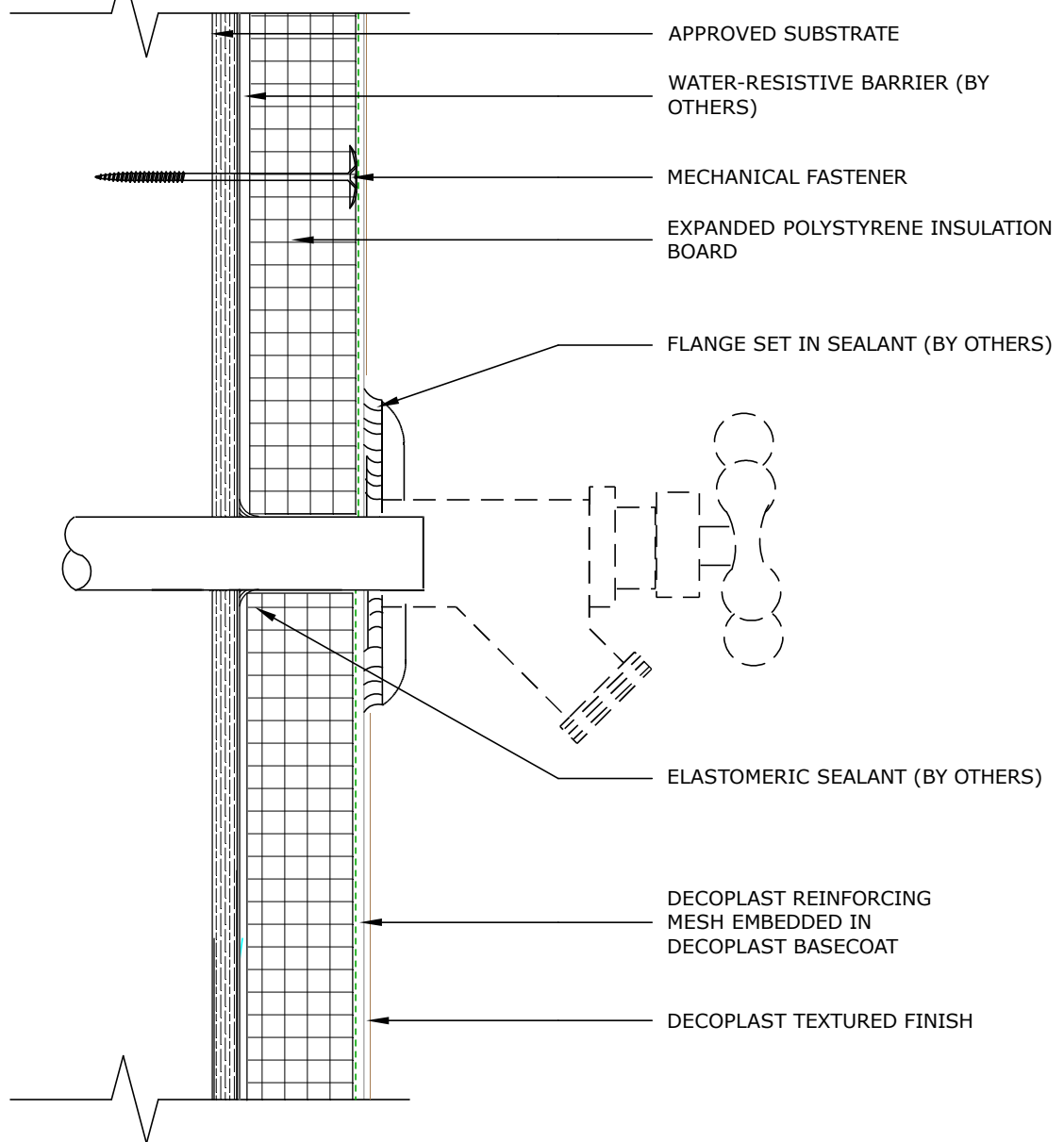

## DDTS P1.02 DTS HERITAGE TERMINATION AT HOSE BIB (BY OTHERS)

DECOPLAST DTS HERITAGE - 6/1/2016

NOTE: See DDTS G1.01A, B or C for Drainage Options.

Disclaimer: The design, specifications, and construction shall comply with all local building codes and standards. Decoplast installation guidelines are for general information and guidance only and Decoplast specifically disclaims any liability for the use of this design, and for design, engineering, or workmanship of any project. The assembly shall be designed to prevent condensation within the assembly. The designer and the user shall provide final drawings and specifications. Products shown other than those manufactured by Decoplast are shown for clarity of the Decoplast product only. Contact the manufacturer of such other products for installation instructions.

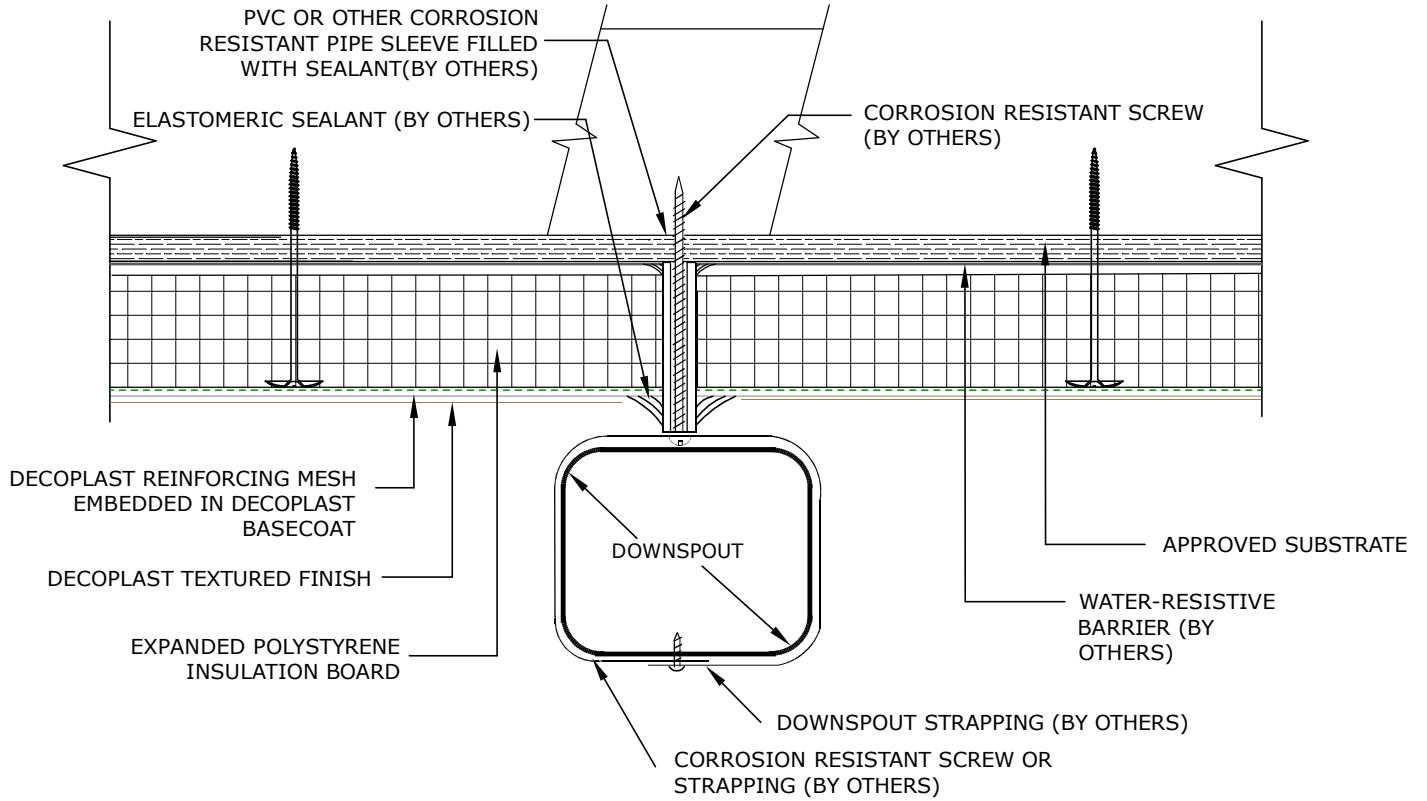

### DDTS P1.03 DTS HERITAGE DOWNSPOUT ATTACHMENT (BY OTHERS)

DECOPLAST DTS HERITAGE

NOTES: See DDTS G1.01 A, B or C for Drainage Options.

Disclaimer: The design, specifications, and construction shall comply with all local building codes and standards. Decoplast installation guidelines are for general information and guidance only and Decoplast specifically disclaims any liability for the use of this design, and for design, engineering, or workmanship of any project. The assembly shall be designed to prevent condensation within the assembly. The designer and the user shall provide final drawings and specifications. Products shown other than those manufactured by Decoplast are shown for clarity of the Decoplast product only. Contact the manufacturer of such other products for installation instructions.



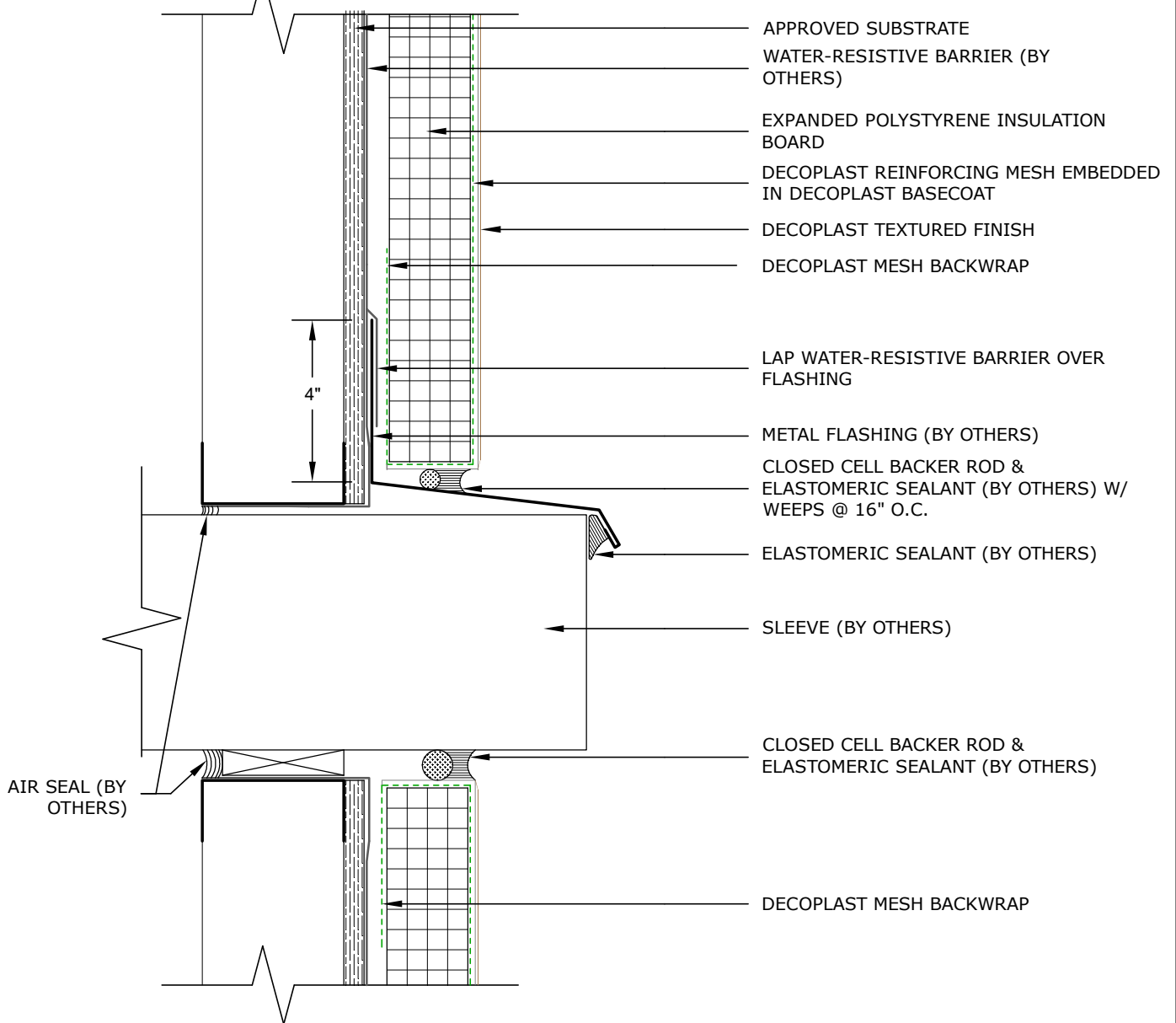

## DDTS P1.04 DTS HERITAGE TERMINATION AT APPLIANCE SLEEVE

DECOPLAST DTS HERITAGE - 6/1/2016

### NOTES:

1. See DDTS G1.01 A, B or C for Drainage Options.
2. See DDTS G 1.02 for Drainage Termination Options.

Disclaimer: The design, specifications, and construction shall comply with all local building codes and standards. Decoplast installation guidelines are for general information and guidance only and Decoplast specifically disclaims any liability for the use of this design, and for design, engineering, or workmanship of any project. The assembly shall be designed to prevent condensation within the assembly. The designer and the user shall provide final drawings and specifications. Products shown other than those manufactured by Decoplast are shown for clarity of the Decoplast product only. Contact the manufacturer of such other products for installation instructions.

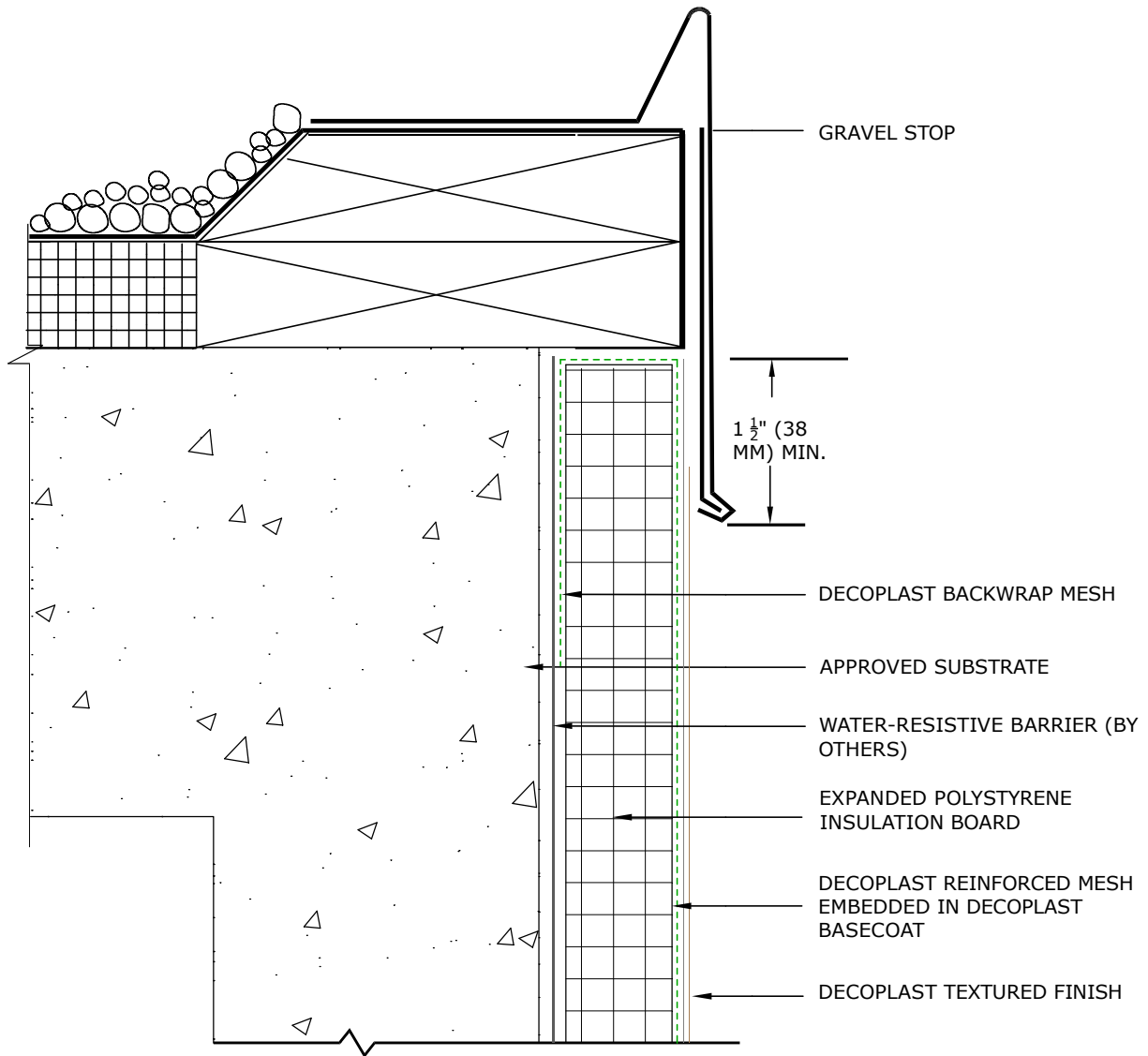

## DDTS R1.04 DTS HERITAGE TERMINATION AT GRAVEL STOP

DECOPLAST DTS HERITAGE - 6/1/2016

### NOTES:

1. See DDTS G1.01 A, B or C for Drainage Options.

Disclaimer: The design, specifications, and construction shall comply with all local building codes and standards. Decoplast installation guidelines are for general information and guidance only and Decoplast specifically disclaims any liability for the use of this design, and for design, engineering, or workmanship of any project. The assembly shall be designed to prevent condensation within the assembly. The designer and the user shall provide final drawings and specifications. Products shown other than those manufactured by Decoplast are shown for clarity of the Decoplast product only. Contact the manufacturer of such other products for installation instructions.

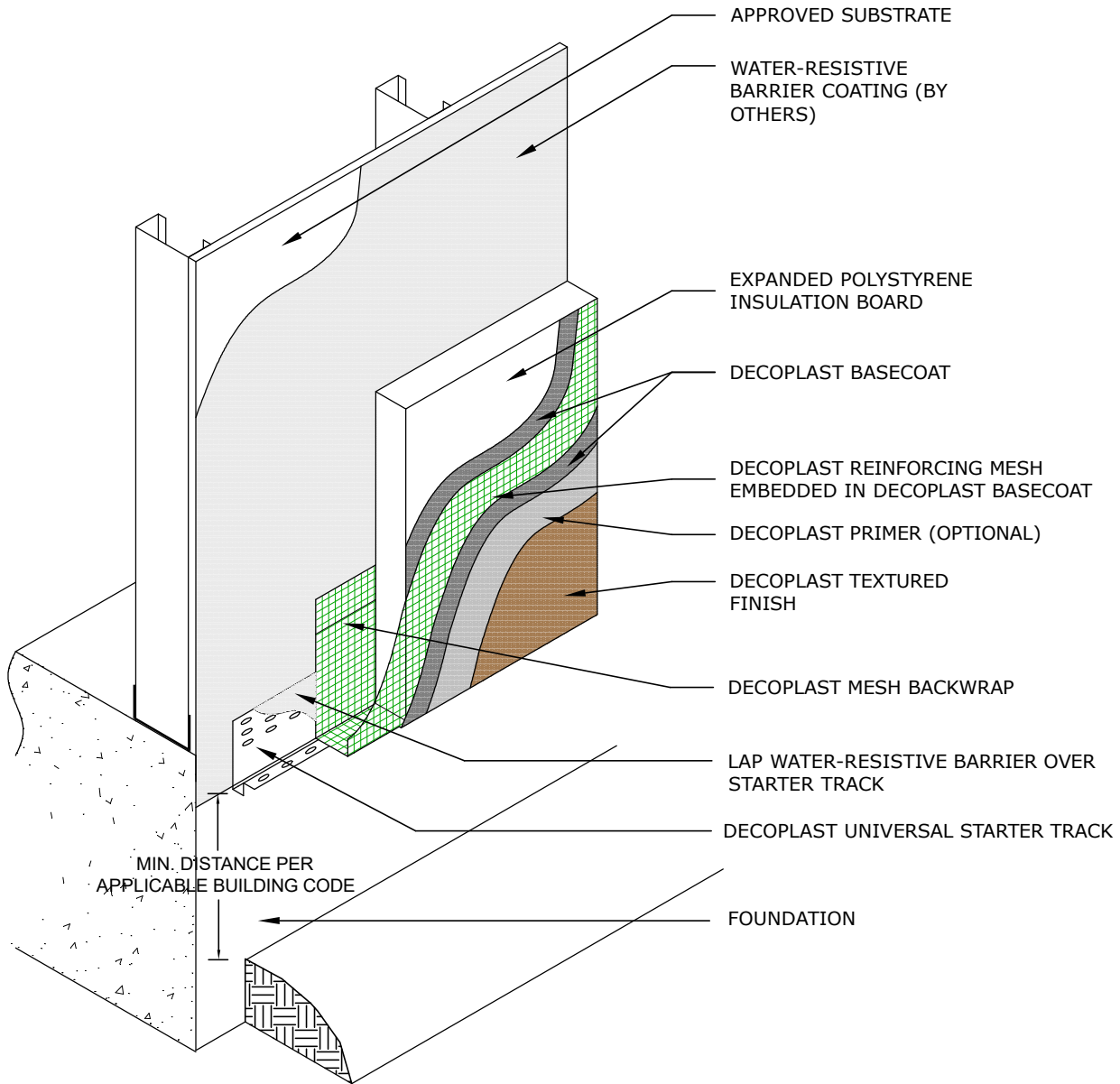

## DDTS T1.02 DTS HERITAGE TERMINATION AT GRADE

DECOPLAST DTS HERITAGE - 6/1/2016

### NOTES:

1. See DDTS G1.01 A, B or C for Drainage Options.
2. See DDTS G1.02 for Termination Options.

Disclaimer: The design, specifications, and construction shall comply with all local building codes and standards. Decoplast installation guidelines are for general information and guidance only and Decoplast specifically disclaims any liability for the use of this design, and for design, engineering, or workmanship of any project. The assembly shall be designed to prevent condensation within the assembly. The designer and the user shall provide final drawings and specifications. Products shown other than those manufactured by Decoplast are shown for clarity of the Decoplast product only. Contact the manufacturer of such other products for installation instructions.

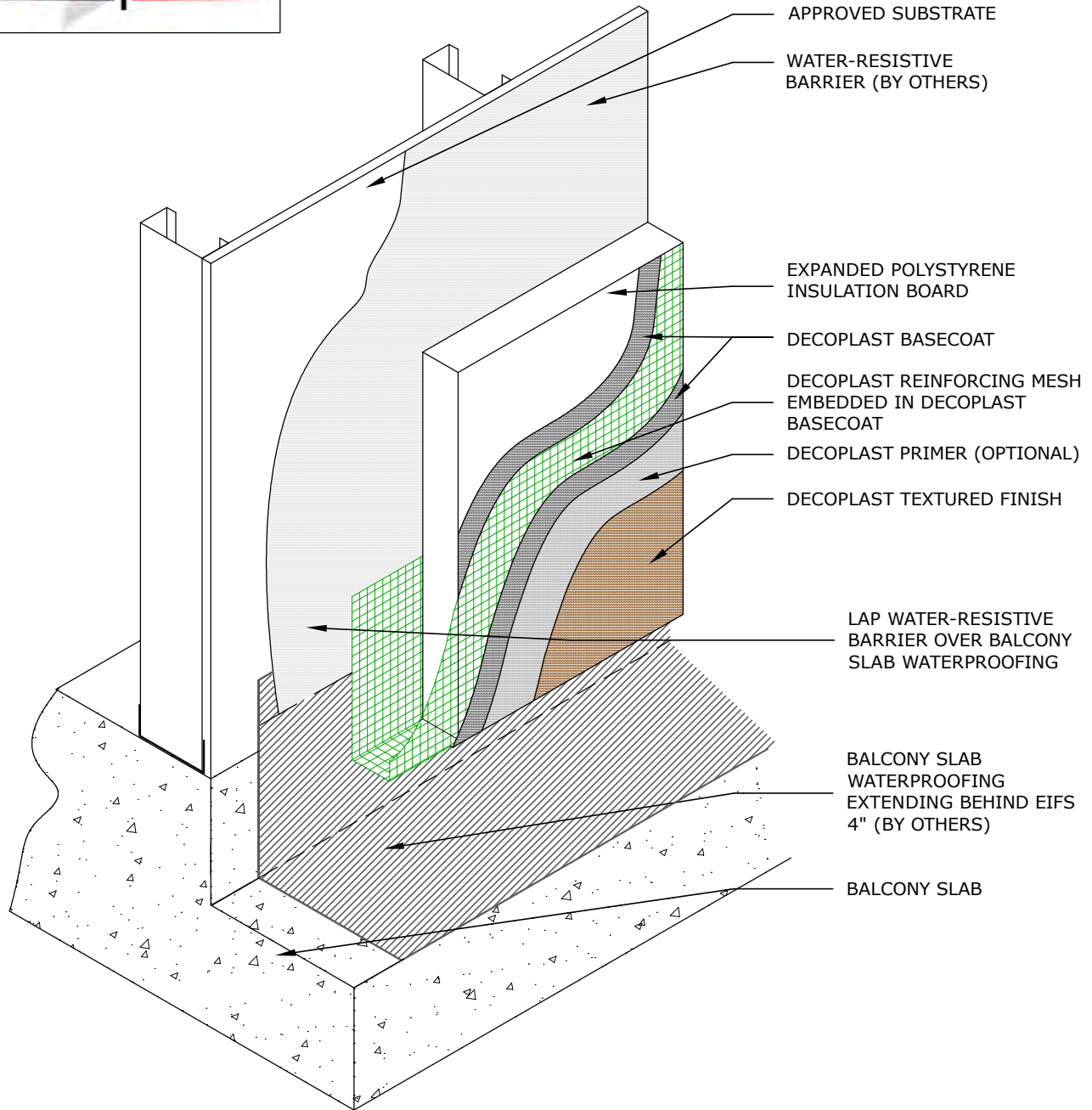

## DDTS T1.05 DTS HERITAGE TERMINATION AT BALCONY SLAB

DECOPLAST DTS HERITAGE - 6/1/2016

### NOTES:

1. See DDTS G1.01 A, B or C for Drainage Options.
2. See DDTS G1.02 for Termination Options.

Disclaimer: The design, specifications, and construction shall comply with all local building codes and standards. Decoplast installation guidelines are for general information and guidance only and Decoplast specifically disclaims any liability for the use of this design, and for design, engineering, or workmanship of any project. The assembly shall be designed to prevent condensation within the assembly. The designer and the user shall provide final drawings and specifications. Products shown other than those manufactured by Decoplast are shown for clarity of the Decoplast product only. Contact the manufacturer of such other products for installation instructions.

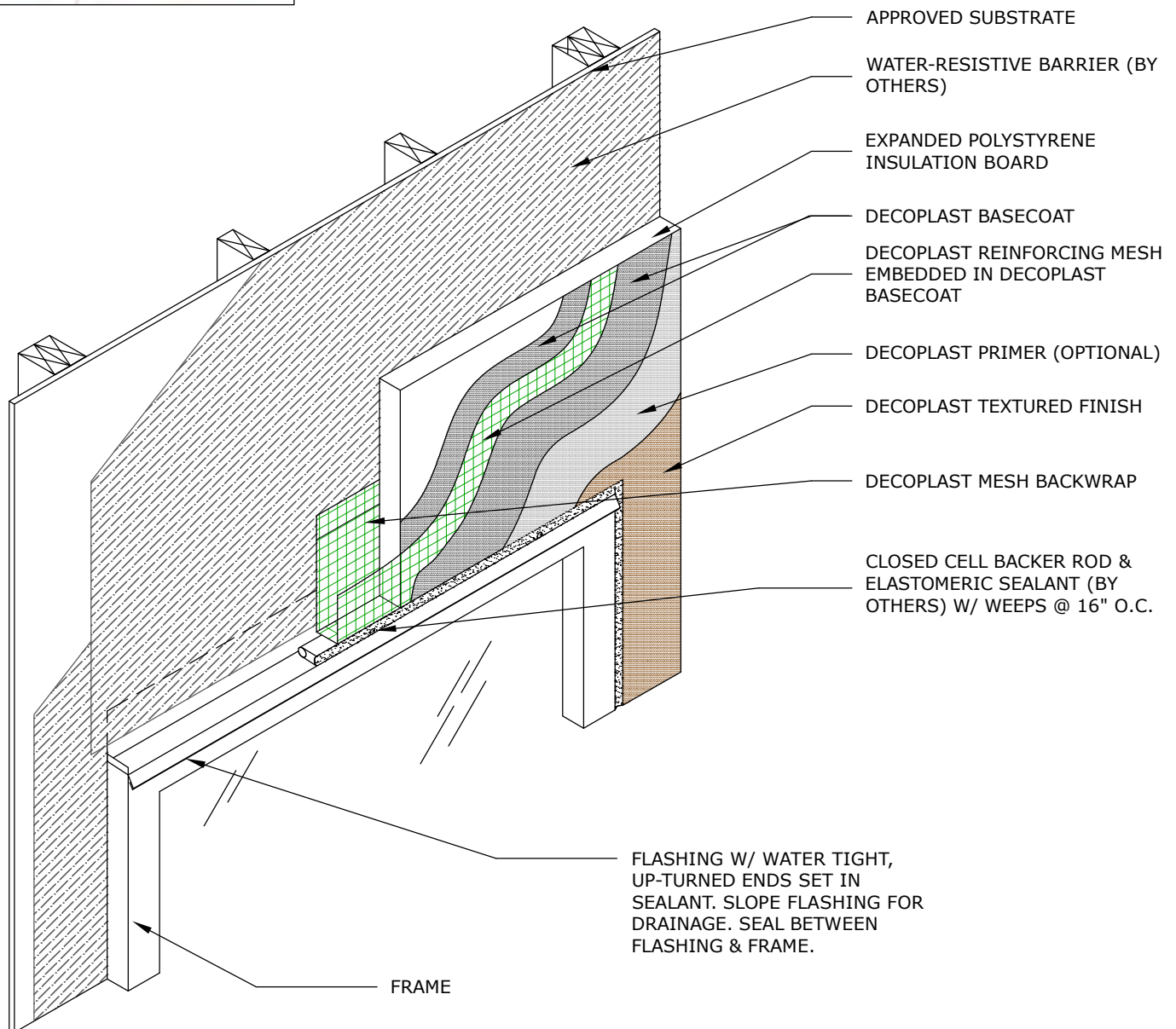

## DDTS W1.01 DTS HERITAGE HEAD ASSEMBLY (WINDOW, DOOR, LOUVER VENTS, ETC.)

DECOPLAST DTS HERITAGE - 6/1/2016

### NOTES:

1. See DDTS G1.01 A, and B for Drainage Options.
2. See DDTS G1.02 for Termination Options.

Disclaimer: The design, specifications, and construction shall comply with all local building codes and standards. Decoplast installation guidelines are for general information and guidance only and Decoplast specifically disclaims any liability for the use of this design, and for design, engineering, or workmanship of any project. The assembly shall be designed to prevent condensation within the assembly. The designer and the user shall provide final drawings and specifications. Products shown other than those manufactured by Decoplast are shown for clarity of the Decoplast product only. Contact the manufacturer of such other products for installation instructions.

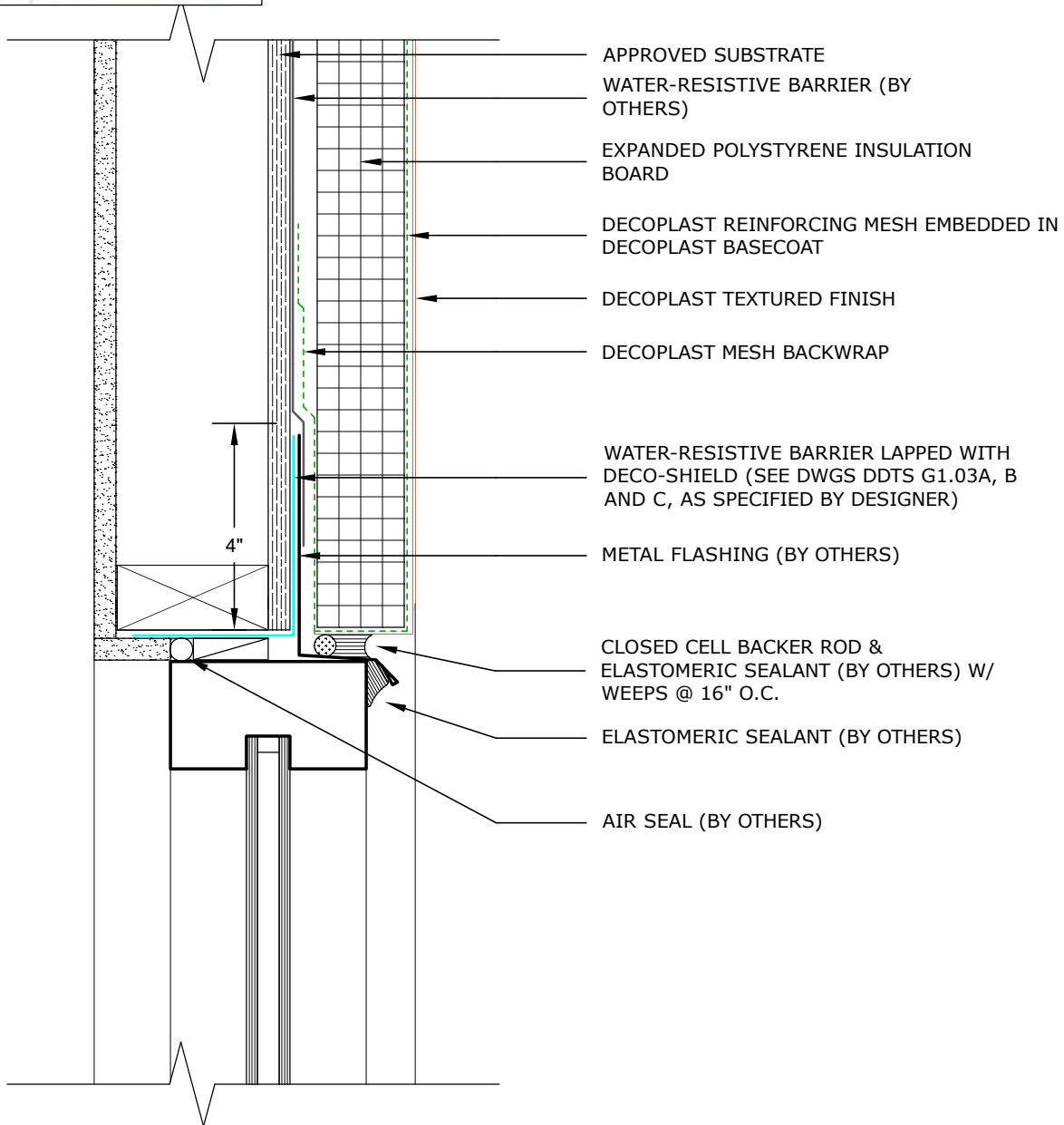

## DDTS W1.02 DTS HERITAGE TERMINATION AT WINDOW HEAD

DECOPLAST DTS HERITAGE - 6/1/2016

### NOTES:

1. See DDTS G1.01 A, B or C for Drainage Options.
2. See DDTS G1.02 for Termination Options.

Disclaimer: The design, specifications, and construction shall comply with all local building codes and standards. Decoplast installation guidelines are for general information and guidance only and Decoplast specifically disclaims any liability for the use of this design, and for design, engineering, or workmanship of any project. The assembly shall be designed to prevent condensation within the assembly. The designer and the user shall provide final drawings and specifications. Products shown other than those manufactured by Decoplast are shown for clarity of the Decoplast product only. Contact the manufacturer of such other products for installation instructions.

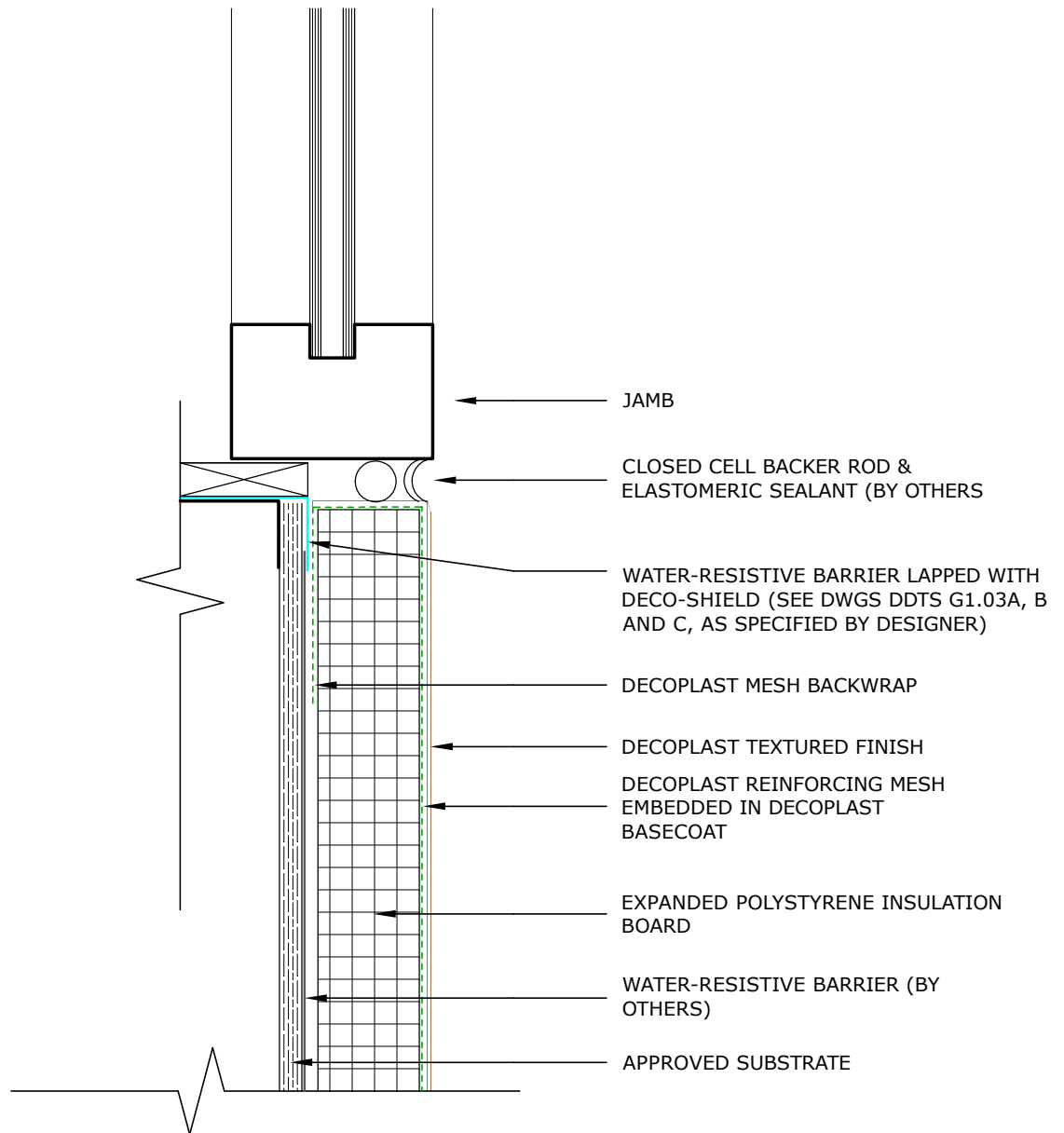

## DDTS W1.04 DTS HERITAGE TERMINATION AT WINDOW JAMB

DECOPLAST DTS HERITAGE - 6/1/2016

**NOTE:**

1. See DDTS G1.01 A, B or C for Drainage Options.

Disclaimer: The design, specifications, and construction shall comply with all local building codes and standards. Decoplast installation guidelines are for general information and guidance only and Decoplast specifically disclaims any liability for the use of this design, and for design, engineering, or workmanship of any project. The assembly shall be designed to prevent condensation within the assembly. The designer and the user shall provide final drawings and specifications. Products shown other than those manufactured by Decoplast are shown for clarity of the Decoplast product only. Contact the manufacturer of such other products for installation instructions.



## Decoplast Liquid Base Coat / Adhesive

### TECHNICAL DATA

REPORT	TEST METHOD	TEST CRITERIA	TEST RESULTS
Surface Burning	ASTM E-84	< 25 Flame Spread	Pass
		< 450 Smoke Developed	Pass
Adhesion (psi)	ASTM C-297	28 days	> 20 Gypsum Sheathing
			> 15 EPS Board
			> 60 Concrete Block
			> 25 Dens-Glass® Gold
NFPA—285			UL Classified

*Decoplast Liquid Base Coat / Adhesive is a 100% acrylic polymer used as an adhesive and base coat combined with Portland Cement. Liquid Base Coat / Adhesive is used in the Decoplast Continuous Insulation Systems. It is a two component product.*

### Coverage

100-125 ft<sup>2</sup> (9.3-11.6 m<sup>2</sup>) per pail, when used for both adhesive and base coat applications.

*Adhesive over sheathing and smooth masonry:*  
200-250 ft<sup>2</sup> (18.6-23.2 m<sup>2</sup>) per pail, application with U-notched trowel having 1-1/2" (38.1mm) spread between notches; 3/8" x 1/2" notch.

*As an adhesive over rough or uneven masonry:*  
Coverage will vary based on surface condition of masonry.

*As a base coat:*  
165-250 ft<sup>2</sup> (15.3-23.2m<sup>2</sup>) per pail.

*As a skim coat:*  
185-250 ft<sup>2</sup> (17.2-23.2m<sup>2</sup>) per pail.

*Coverages may vary depending on application technique and surface conditions.*

### Packaging

5 gal. (19L) pail 62.5 lbs / 28.4 kg per pail

### Shelf Life

24 months, if unopened, properly stored and protected from moisture.

### Storage

Store off the ground in a dry area. Protect from extreme heat [90°F (32°C)], moisture and direct sunlight.

### FEATURES BENEFITS

<b>Polymer-modified</b>	Excellent adhesion; increases durability and freeze/thaw resistance
<b>Smooth consistency</b>	Trowels on easily; increases productivity
<b>Vapor Permeable</b>	Use as an adhesive, base coat and leveling coat

### SURFACE PREPARATION

#### Adhesive Preparation:

**Decoplast Liquid Weather Resistive Barrier:** ensure surface is clean, dry and free of surface contamination. Install insulation board with adhesive within 30 days of the application of Decoplast Liquid Weather Resistive Barrier, or clean the surface and recoat with Decoplast Liquid Weather Resistive Barrier.

#### Concrete or Masonry

Surfaces must be clean, dry and free of frost, damage and all bond inhibiting materials, including dirt, efflorescence, laitance, form oil and other foreign matter. Loose or damaged material must be removed by water blasting, sandblasting or mechanical wire brushing and repaired. Avoid application over irregular surfaces. Resurface, patch or level surfaces to required tolerance and smoothness with appropriate Decoplast leveling materials.

#### Glass Mat Gypsum Sheathing in Compliance with ASTM C 1177

Ensure surface is clean, dry and free of surface contamination. Sheathing must be installed and protected in accordance with manufacturer's and building code requirements. Remove and replace weather damaged sheathing. Avoid application over irregular, out of plane surfaces. Install insulation board with adhesive within 30 days of installation of the sheathing.

#### As a Base Coat

#### Insulation Board

Insulation must be rasped and free of all bond inhibiting materials.

#### Concrete or Masonry

Surfaces must be clean, dry and free of frost, damage and all bond-inhibiting materials, including dirt, efflorescence, laitance, form oil and other foreign matter. Loose or damaged material must be removed by water blasting, sandblasting or mechanical wire brushing and repaired.



## Decoplast Liquid Base Coat / Adhesive



### MIXING

Mix equal parts of Decoplast Liquid Base Coat / Adhesive to Type I/ II Portland cement by weight. Mix with a clean, rust-free electric drill and paddle. Allow to set approximately five minutes, adjust mix if necessary by adding up to 8 fl. oz. (0.24 L) of water, and remix to a uniform consistency. Avoid retempering after mixing of product.

### APPLICATION

Apply only to sound and clean, dry, properly prepared, frost-free surfaces.

#### As an Adhesive:

Apply to the back of the insulation board with the appropriate size notched trowel. Form uniform ribbons of adhesive parallel to the short dimension of the board so the ribbons are oriented vertically in relation to the plane of the wall. Immediately install the board horizontally with staggered joints and apply firm uniform pressure over the entire board surface. Do not delay installation once adhesive is applied.

#### As a Base Coat:

Apply with a stainless steel trowel to an approximate thickness of 1/8" (3 mm). Work horizontally or vertically in strips of 40" (1 m) and immediately embed Decoplast Reinforcing Mesh in wet base coat by troweling from the center to the edges of the mesh. Avoid wrinkles in the mesh and smooth the base coat to eliminate trowel marks. Minimum recommended dry thickness of the reinforced base coat is 1/16" (1.6 mm) when dry. Reapply additional base coat if necessary to achieve minimum thickness as soon as the first application is dry. Embedded mesh in base coat should not be visible.

#### As a Skim Coat:

Apply with a stainless steel trowel to a maximum thickness of 1/16" to the prepared surface.

#### Curing/Drying

Dries within 24 hours under normal drying conditions [70°F (21°C), 50% RH]. Allow additional drying time during cold, humid, or wet weather until insulation board is fully adhered before rasping, and before application of primer or finish to hardened Decoplast Liquid Base Coat. Protect from rain, freezing and continuous high humidity until completely dry. Decoplast recommends using Decoplast Primer prior to application of finish.

#### Clean Up

Clean tools and equipment with water immediately after use. Dried material can only be removed mechanically.

### LIMITATIONS

Use Decoplast Liquid Base Coat only when surface and ambient temperatures are above 40°F (4°C) during application and drying period.

Sloped surfaces: Refer to Decoplast details.

Decoplast Liquid Base Coat should not be used on weather-exposed horizontal or below grade surfaces or where immersion in water may occur.

Prevent rapid loss of moisture from exposure to direct sun, wind and high temperatures.

Decoplast Liquid Base Coat should not be used as a finish coating.

### HEALTH AND SAFETY

#### Health Precaution

Decoplast Liquid Base Coat is water-based. As with any chemical construction product, exercise care when handling.

#### WARNING!

Causes eye and skin irritation.

#### Safety Precaution

Wash hands thoroughly after handling. Wear protective gloves/protective clothing/eye protection/face protection.

#### First Aid:

**EYE CONTACT:** Immediately flush eyes with plenty of water for at least 15 to 20 minutes. Ensure adequate flushing of the eyes by separating the eye lids with fingers. Get immediate medical attention.

**SKIN CONTACT:** Immediately wash skin with plenty of soap and water for at least 15 to 20 minutes, while removing contaminated clothing and shoes. Get medical attention if irritation develops or persists.

**INHALATION:** If inhaled, remove to fresh air. If not breathing give artificial respiration or give oxygen by trained personnel. Seek medical attention immediately.

**INGESTION:** If swallowed, do NOT induce vomiting. Call a physician or a poison control center immediately. Never give anything by mouth to an unconscious person.

#### Spills

Contain and collect in an appropriate container. Uncured material may be removed with water.

#### Disposal

Dispose of in accordance with local, state or federal regulations.

#### Warning

KEEP CONTAINER CLOSED WHEN NOT IN USE. KEEP OUT OF THE REACH OF CHILDREN. NOT FOR INTERNAL CONSUMPTION. FOR INDUSTRIAL USE ONLY. Consult the Safety Data Sheet (SDS) for further health and safety information.

#### LIMITED WARRANTY

This product is subject to a written limited warranty. Refer to Decoplast Specifications for more complete information on proper use and handling of this product.



This product is intended for use by qualified professional contractors. All information conforms to the standard detail recommendations and specifications for the installation of Decoplast systems and is presented in good faith as of the date of publication of this document. GREENMAKER INDUSTRIES ASSUMES NO LIABILITY, EXPRESSED OR IMPLIED, AS TO THE WORKMANSHIP, ENGINEERING OR ARCHITECTURE OF ANY PROJECT. For more information regarding this product or additional Decoplast products, please contact a Decoplast Representative at (860) 761-2830 or visit our website [www.Decoplast.com](http://www.Decoplast.com).

## Decoplast Dry Base Coat / Adhesive Premium



### TECHNICAL DATA

REPORT	TEST METHOD	TEST CRITERIA	TEST RESULTS
Surface Burning	ASTM E-84	< 25 Flame Spread	Pass
		< 450 Smoke Developed	Pass
Adhesion (psi)	ASTM C-297	28 days	> 20 Gypsum Sheathing
			> 15 EPS Board
			> 80 Concrete Block
			> 35 Dens-Glass® Gold

*Decoplast Dry Base Coat / Adhesive Premium is a one component, polymer-modified, cement based, dry powder material used as an adhesive and base coat used in the Decoplast Continuous Insulation Systems.*

### FEATURES

**One-component**  
**Polymer-modified**  
**Smooth consistency**  
**Vapor permeable**  
**Factory blended Portland Cement**  
**Low cement ratio**  
**Bagged powder product**

### BENEFITS

Ready to use; easily mixed with water on the job site  
 Excellent adhesion; increases durability and freeze/thaw resistance  
 Trowels on easily; increases productivity  
 Allows substrate to breathe naturally; resists blistering due to vapor  
 Assures performance mix ratio  
 Less alkalinity, less free lime, less efflorescence  
 Less solid waste

### SURFACE PREPARATION

#### Adhesive Preparation:

Ensure surface is clean, dry and free of surface contamination. Install insulation board with adhesive within 30 days of the application of **Decoplast Weather-Resistive Barrier** or clean the surface and recoat with **Decoplast Weather-Resistive Barrier**.

#### Concrete / Masonry

Surfaces must be clean, dry and free of frost, damage and all bond inhibiting materials, including dirt, efflorescence, laitance, form oil and other foreign matter. Loose or damaged material must be removed by water blasting, sandblasting or mechanical wire brushing and repaired. Avoid application over irregular surfaces. Resurface, patch or level surfaces to required tolerance and smoothness with appropriate Decoplast leveling materials.

#### ASTM C 1177— Glass Mat Gypsum Sheathing

Ensure surface is clean, dry and free of surface contamination. Sheathing must be installed and protected in accordance with manufacturer’s and building code requirements. Remove and replace weather damaged sheathing. Avoid application over irregular, out of plane surfaces. Install insulation board with adhesive within 30 days of installation of the sheathing.

#### Base Coat Preparation:

Insulation board must be rasped and free of all bond inhibiting materials.

#### Concrete or Masonry

Surfaces must be clean, dry and free of frost, damage and all bond inhibiting materials, including dirt, efflorescence, laitance, form oil and other foreign matter. Loose or damaged material must be removed by water blasting, sandblasting or mechanical wire brushing and repaired.

### Coverage

75 – 100 ft<sup>2</sup> (6.9-9.29 m<sup>2</sup>) per bag, used for both adhesive and base coat applications.

#### Adhesive over sheathing and smooth masonry:

200-240 ft<sup>2</sup> (18.6-22.3 m<sup>2</sup>) per bag, application with U-notched trowel having 1-1/2” (38 mm) spread between notches; 3/8” x 1/2” notch.

#### Adhesive over rough or uneven masonry:

95-115 ft<sup>2</sup> (8.8-11.1 m<sup>2</sup>) per bag, application with U-notched trowel having 1-1/2” (38 mm) spread between notches; 3/8” x 1/2” x 1/2” notch.

#### Skim coat:

90-135 ft<sup>2</sup> (8.4-12.5 m<sup>2</sup>) per bag

*Coverages may vary depending on application technique and surface conditions.*

### Packaging

50 lb. bag (23 kg).

### Shelf Life

24 months, if unopened, properly stored and protected from moisture.

### Storage

Store off the ground in a dry area. Protect from extreme heat [90°F (32°C)], moisture and direct sunlight.

## Decoplast Dry Base Coat / Adhesive Premium



### MIXING

Use 5-6.5 quarts (4.7-6.2 L) of clean, potable water per 50 lb. (23 kg) bag of Decoplast Dry Base Coat. Mix with a clean, rust-free electric drill and paddle. Allow to set approximately five minutes, adjust mix if necessary by adding up to 12 fl.oz. (0.35 L) of water per bag, remix to a uniform consistency. Avoid re-tempering after mixing of product. Do not exceed maximum amount of water in mix ratio.

### APPLICATION

Apply only to sound and clean, dry, properly prepared, frost-free surfaces.

#### As an Adhesive:

Apply to the back of the insulation board with the appropriate size notched trowel. Form uniform ribbons of adhesive parallel to the short dimension of the board so the ribbons are oriented vertically in relation to the plane of the wall. Immediately install the board horizontally with staggered joints and apply firm uniform pressure over the entire board surface. Do not delay installation once adhesive is applied.

#### As a Base Coat:

Apply with a stainless steel trowel to an approximate thickness of 1/8" (3 mm). Work horizontally or vertically in strips of 40" (1 m) and immediately embed Decoplast Reinforcing Mesh in wet base coat by troweling from the center to the edges of the mesh. Avoid wrinkles in the mesh and smooth the base coat to eliminate trowel marks. Minimum recommended dry thickness of the reinforced base coat is 1/16" (1.6 mm) when dry. Reapply additional base coat if necessary to achieve minimum thickness as soon as the first application is dry. Embedded mesh in base coat should not be visible.

#### As a Skim Coat:

Apply in one application to a maximum thickness of 1/16" (1.6 mm) to the prepared surface and smooth the surface.

#### Curing/Drying

Dries within 24 hours under normal drying conditions [70°F (21°C), 50% RH]. Allow additional drying time during cold, humid, or wet weather until insulation board is fully adhered before rasping, and before application of primer or finish to hardened Decoplast Dry Base Coat. Protect from rain, freezing and continuous high humidity until completely dry. Decoplast recommends using Decoplast Primer prior to application of finish.

#### Clean Up

Clean tools and equipment with water immediately after use. Dried material can only be removed mechanically.

### LIMITATIONS

Use Decoplast Dry Base Coat only when surface and ambient temperatures are above 40°F (4°C) during application and drying period.

Sloped surfaces: Refer to Decoplast details.

Decoplast Dry Base Coat should not be used on weather-exposed horizontal or below grade surfaces or where immersion in water may occur.

Prevent rapid loss of moisture from exposure to direct sun, wind and high temperatures.

Decoplast Dry Base Coat should not be used as a finish coating.

### HEALTH AND SAFETY

#### Health Precaution

Contains Portland cement and crystalline-free silica. Avoid breathing dust. As with any chemical construction product, exercise care when handling.

#### DANGER!

Causes serious eye damage and/or skin irritation. May cause an allergic skin reaction, respiratory irritation, drowsiness or dizziness.

#### Safety Precaution

Wash hands thoroughly after handling. Wear protective gloves/protective clothing/eye protection/face protection.

#### First Aid:

**EYE CONTACT:** Immediately flush eyes with plenty of water for at least 15 to 20 minutes. Ensure adequate flushing of the eyes by separating the eye lids with fingers. Get immediate medical attention.

**SKIN CONTACT:** Immediately wash skin with plenty of soap and water for at least 15 to 20 minutes, while removing contaminated clothing and shoes. Get medical attention if irritation develops or persists.

**INHALATION:** If inhaled, remove to fresh air. If not breathing give artificial respiration or give oxygen by trained personnel. Seek medical attention immediately.

**INGESTION:** If swallowed, do NOT induce vomiting. Call a physician or a poison control center immediately. Never give anything by mouth to an unconscious person.

#### Spills

Contain and collect in an appropriate container. Uncured material may be removed with water.

#### Disposal

Dispose of in accordance with local, state or federal regulations.

#### Warning

KEEP CONTAINER CLOSED WHEN NOT IN USE. KEEP OUT OF THE REACH OF CHILDREN. NOT FOR INTERNAL CONSUMPTION. FOR INDUSTRIAL USE ONLY. Consult the Safety Data Sheet (SDS) for further health and safety information.

#### LIMITED WARRANTY

This product is subject to a written limited warranty. Refer to Decoplast Specifications for more complete information on proper use and handling of this product.



This product is intended for use by qualified professional contractors. All information conforms to the standard detail recommendations and specifications for the installation of Decoplast systems and is presented in good faith as of the date of publication of this document. GREENMAKER INDUSTRIES ASSUMES NO LIABILITY, EXPRESSED OR IMPLIED, AS TO THE WORKMANSHIP, ENGINEERING OR ARCHITECTURE OF ANY PROJECT. For more information regarding this product or additional Decoplast products, please contact a Decoplast Representative at (860) 761-2830 or visit our website [www.Decoplast.com](http://www.Decoplast.com).

**EPS Foam Board (Expanded Polystyrene)**



**INSULATION BOARD PROPERTIES**

	TEST METHOD	VALUES		
<b>MOISTURE RESISTANCE</b>				
Water Vapor Transmission	ASTM E-96	2.0-5.0 Perms		
Water Absorption	ASTM C-272	Less than 4% by Volume		
<b>STRENGTH PROPERTIES</b>				
Compressive 10% Deflection	ASTM D-1621	10-14 psi		
Flexural Strength	ASTM C-203	25-30 psi		
Tensile Strength	ASTM D-1623	16-20 psi		
<b>SURFACE BURNING CHARACTERISTICS</b>				
Flame Spread	ASTM E-84	<25		
Fuel Contributed	ASTM E-84	Not Determinable		
Smoke Development	ASTM E-84	<450		
<b>THERMAL PROPERTIES (1" THICK BOARD)</b>				
Thermal Resistance @ 75°F	ASTM C-177-C518	R=3.6 ft <sup>2</sup> -f-h/BTU		
Thermal Resistance @ 40°F	ASTM C-177-C518	R=4.0 ft <sup>2</sup> -f-h/BTU		
Thermal Resistance @ 40°F	ASTM C-177-C518	U=0.25		
Coefficient of Thermal Expansion	ASTM D-696	0.000035 in/in-F		
DENSITY	ASTM C-303	0.9 LBS/cu ft min		
INSULATION THICKNESS	<b>1"</b>	<b>2"</b>	<b>3"</b>	<b>4"</b>
"R" Value	3.9	7.7	11.6	15.4

Expanded Polystyrene (EPS) Foam Boards are an integral part of an EIFS system. Available in various thicknesses, flat or grooved, EPS Foam Boards provide insulative qualities as well as drainage capabilities for moisture release systems.

- 1/2" Thickness: 36 Pieces/Bundle—288 ft<sup>2</sup>**
- 3/4" Thickness: 27 Pieces/Bundle—216 ft<sup>2</sup>**
- 1" Thickness: 18 Pieces/Bundle—144 ft<sup>2</sup>**
- 1-1/2" Thickness: 12 Pieces/Bundle—96ft<sup>2</sup>**
- 2" Thickness: 8 Pieces/Bundle—72 ft<sup>2</sup>**
- 3" Thickness: 6 Pieces/Bundle—48 ft<sup>2</sup>**
- 4" Thickness: 4 Pieces/Bundle—36 ft<sup>2</sup>**
- 6" Thickness: 3Pieces/Bundle—24 ft<sup>2</sup>**

\*Note: Boards to be installed in compliance to IBC 1705.15 section 1704.14.1 of the 2009 IBC.

**MANUFACTURER REQUIREMENTS**

- Radco #1182 Approved
- Only 100% virgin expandable polystyrene resin is to be used. The use of any regrind material is strictly forbidden.
- Density must be 1" or greater.
- Molded blocks shall be air dried for a minimum of six weeks (less than .5% residual pentane) prior to cutting into finished boards: +/- 1/32 inch
- Over entire board of a maximum size (2 x 4 ASTM C-550) length, width, thickness and squareness: +/- 1/16 inch. Flatness over entire board: +/- 1/32 inch

**Limitations**

- Installed boards not to be left exposed >30 days.
- If yellowing occurs, sand surface until yellowing is removed.
- Any boards less than 3/4" thickness after rasping must be removed and replaced.

**Storage**

Protect from extreme heat and direct sunlight.

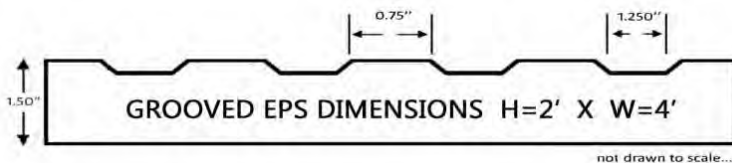

This product is intended for use by qualified professional contractors. All information conforms to the standard detail recommendations and specifications for the installation of Decoplast systems and is presented in good faith as of the date of publication of this document. GREENMAKER INDUSTRIES ASSUMES NO LIABILITY, EXPRESSED OR IMPLIED, AS TO THE WORKMANSHIP, ENGINEERING OR ARCHITECTURE OF ANY PROJECT. For more information regarding this product or additional Decoplast products, please contact a Decoplast Representative at (860) 761-2830 or visit our website [www.Decoplast.com](http://www.Decoplast.com).



**EPS Foam Board (Expanded Polystyrene)**

**EPS — RUNNING BOND APPLICATION**

This illustration is designed to show the correct application methods by which to apply Decoplast Expanded Polystyrene Board (EPS) to any approved substrate. This process ensures that the structural integrity of the critical application phase which governs every subsequent product(s) that are adhered to these foam boards.

Refer to the notations below. This is NOT intended to be a construction document drawing. Consult with a Decoplast professional if you have any questions or to learn more about any or all phases of EIFS applications, systems and products.

Note: Boards to be installed in compliance to IBC 1705.15 section 1704.14.1 of the 2009 IBC.

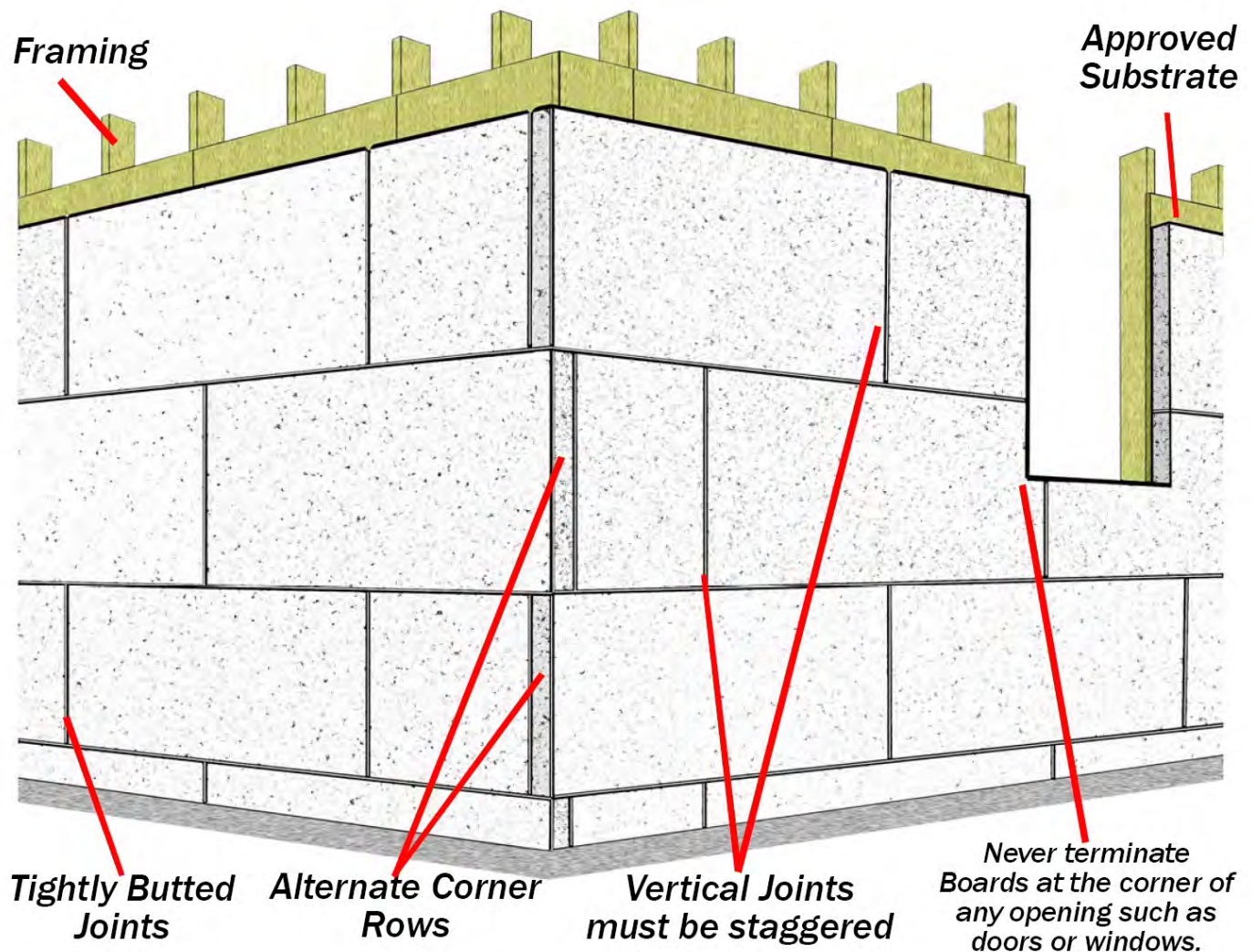

EPS Foam Board (Expanded Polystyrene)



EPS FASTENER — FASTENING PATTERN

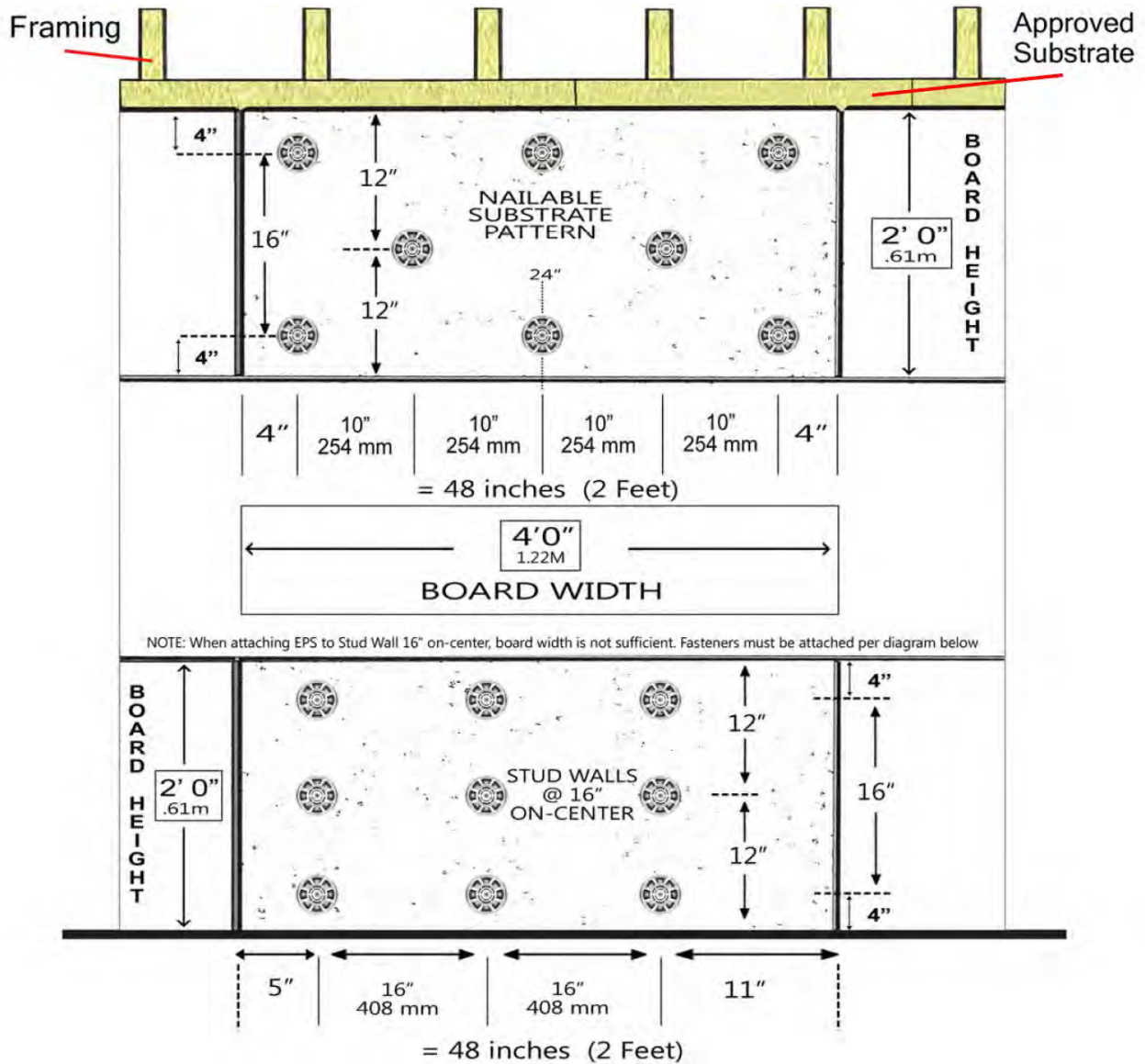



## Decoplast Fiberglass Reinforcing Mesh

Detail Mesh (4.5 oz) / Standard Mesh (4.5 oz)  
 High Standard Mesh (6.0 oz) / Intermediate Mesh (10.0 oz)  
 Decoplast Armor 15 Mesh (14.0 oz) / Decoplast Armor 20 Mesh (20.0 oz)  
 Decoplast Corner Mesh (6.0 oz)

*Decoplast Reinforcing Meshes are specially designed coated glass fiber fabrics used as base coat reinforcement and for impact resistance wall applications.*

### TECHNICAL DATA

REPORT	TEST METHOD	TEST CRITERIA	TEST RESULTS	
Tensile Strength	ASTM D-5035	Product	WARP (PLI)	WEFT (PLI)
		Detail Mesh	150	160
		Standard Mesh	150	160
		High Standard Mesh	140	225
		Intermediate Mesh	300	460
		Armor 15	350	540
		Armor 20	875	500
		Corner Mesh	140	225

#### Coverage Per Roll

Decoplast Detail Mesh: 118 ft<sup>2</sup> (11 m<sup>2</sup>)  
 Standard Mesh: 475 ft<sup>2</sup> (44.1 m<sup>2</sup>)  
 High Standard: 475 ft<sup>2</sup> (44.1 m<sup>2</sup>)  
 Intermediate Mesh: 237 ft<sup>2</sup> (22.1 m<sup>2</sup>)  
 Armor 15: 237 ft<sup>2</sup> (22.1 m<sup>2</sup>)  
 Armor 20: 237 ft<sup>2</sup> (22.1 m<sup>2</sup>)  
 Decoplast Corner Mesh: 118 ft<sup>2</sup> (11 m<sup>2</sup>)

Product	Nominal Weight (YD <sup>2</sup> . +/- 5 %)	Width of Roll	Length of Roll
Detail Mesh	4.5 oz	9.5" (0.24 m)	150' (45.7 m)
Standard Mesh	4.5 oz	38" (0.97 m)	150' (45.7 m)
High Standard	6.0 oz	38" (0.97 m)	150' (45.7 m)
Intermediate	10.0 oz	38" (0.97 m)	75' (22.9 m)
Armor 15	14.0 oz	38" (0.97 m)	75' (22.9 m)
Armor 20	20.0 oz	39" (0.97 m)	75' (22.9 m)
Corner Mesh	6.0 oz	9.5" (0.24 m)	150' (45.7 m)

#### Packaging Per Carton

Decoplast Detail Mesh: 16 Rolls / Box  
 Standard Mesh: 4 Rolls / Box  
 High Standard: 4 Rolls / Box  
 Intermediate Mesh: 4 Rolls / Box  
 Armor 15: 2 Rolls / Box  
 Armor 20: 1 Rolls / Box  
 Decoplast Corner Mesh: 4 Rolls / Box

### FEATURES BENEFITS

<b>Flexible</b>	Easily wrapped at corners; provides crack resistance
<b>Trimmed Edges</b>	Minimizes building on overlapped seams
<b>Coated Glass Fiber</b>	Durable, long-lasting; provides impact resistance
<b>Variety of Weights</b>	Meets a variety of requirements

#### Shelf Life

24 months, if unopened, properly stored and protected from moisture.

### USE

Decoplast Intermediate Mesh: for use as a reinforcing fabric in wall claddings. Achieves high-impact resistance.

Decoplast Detail Mesh: lightweight, highly flexible reinforcing fabric specially designed for use to facilitate back-wrapping system terminations, into reveals and for intricate architectural details in wall claddings, and to bridge sheathing joints and wrap rough openings applications.

Decoplast Mesh / High Standard: for use as standard reinforcing fabric in wall claddings, and in Autoclaved Aerated Concrete (AAC) wall applications. Achieves standard impact resistance.

#### Storage

Store off the ground in a dry area. Protect from extreme heat [90°F (32°C)], moisture and direct sunlight.



## Decoplast Fiberglass Reinforcing Mesh

Detail Mesh (4.5 oz) / Standard Mesh (4.5 oz)  
High Standard Mesh (6.0 oz) / Intermediate Mesh (10.0 oz)  
Decoplast Armor 15 Mesh (14.0 oz) / Decoplast Armor 20 Mesh (20.0 oz)  
Decoplast Corner Mesh (6.0 oz)

### USE CONTINUED

Decoplast Armor 15: for use at ground floors and other areas of anticipated impact in wall claddings. Achieves ultra-high impact resistance when used beneath Decoplast Mesh.

Decoplast Armor 20: Decoplast's heaviest reinforcing fabric, for use at ground floors and other areas of anticipated impact in wall claddings. Exceeds ultra-high impact resistance when used beneath Decoplast Mesh.

### SURFACE PREPARATION

Inspect the insulation board surface for planeness, damage or deterioration due to weather or abuse, and repair prior to application of reinforcing mesh. Rasp the insulation board surface.

### APPLICATION

Decoplast Intermediate Mesh / Decoplast Mesh / High Standard Mesh:  
Apply a layer of base coat over previously rasped insulation board (or, over cement board stucco systems, or, over prepared AAC wall applications). Work horizontally or vertically in full width strips and fully embed mesh into wet base coat by troweling from center to the edges of the mesh. Avoid wrinkles in the mesh and smooth the base coat to eliminate trowel marks. Double wrap mesh at all corners and overlap not less than 2½" (64 mm) at mesh joints.

Decoplast Detail Mesh: Refer to appropriate Decoplast wall claddings specifications.

Decoplast Armor 15 / Armor 20: Apply a layer of Decoplast base coat over previously rasped insulation board. Work horizontally or vertically in full width strips and immediately embed Armor Mesh into the wet base coat. Butt Decoplast Armor Mesh tightly at seams. Apply Decoplast Mesh with appropriate base coat over the Armor Mesh application when dry.

### LIMITATIONS

Decoplast Reinforcing Meshes should only be used in accordance with appropriate Decoplast Insulated Wall Cladding Specification or other published recommendations.

### HEALTH AND SAFETY

#### Health Precaution

Contains fiberglass. As with any chemical construction product, exercise care when handling.

#### Safety Precaution

Wash hands thoroughly after handling. Wear protective gloves/protective clothing/eye protection/face protection.

#### First Aid:

EYE CONTACT: Immediately flush eyes with plenty of water for at least 15 to 20 minutes. Contact a physician.

#### Disposal

Dispose of in accordance with local, state or federal regulations.

#### Warning

KEEP CONTAINER CLOSED WHEN NOT IN USE. KEEP OUT OF THE REACH OF CHILDREN. NOT FOR INTERNAL CONSUMPTION. FOR INDUSTRIAL USE ONLY. Consult the Safety Data Sheet (SDS) for further health and safety information.

#### LIMITED WARRANTY

This product is subject to a written limited warranty. Refer to Decoplast Specifications for more complete information on proper use and handling of this product.





# Decoplast Primer

64 Standard Colors / Custom Colors

## TECHNICAL DATA

REPORT	TEST METHOD	TEST CRITERIA	TEST RESULTS
Surface Burning	ASTM E-84	< 25 Flame Spread	Pass
		< 450 Smoke Developed	Pass

## FEATURES BENEFITS

<b>Acrylic Based</b>	Excellent adhesion; finish coat adhesion improvement
<b>Tinted for Finish</b>	Color uniformity improvement
<b>Substrate Absorption</b>	Improves coverage, water-resistance, and reduces possible efflorescence
<b>Non Vapor Barrier</b>	Allows substrate to breathe naturally
<b>Water-Based</b>	Safe, non-toxic; cleans up with water
<b>Low VOC</b>	Safe for workers and the environment

## SURFACE PREPARATION

Surfaces must be clean, dry, and free of frost, damage, releasing agents, including dirt, efflorescence, form oil and other foreign matter. Loose or damaged material must be removed by water blasting, sandblasting or mechanical wire brushing and repaired. Avoid application over irregular surfaces. Resurface, patch or level surfaces to required tolerance and smoothness with appropriate Decoplast leveling materials.

Pressure washing is a recommended means of surface preparation. Follow necessary safety precautions and adjust pressure to avoid damage to the underlying substrate or substrate condition. For mold, algae, and mildew removal, treat surfaces with a commercial mildew removal and/or wash product carefully following manufacturer's application and safety directions.

*Decoplast Primer is used for priming prepared concrete, masonry, plaster, EIFS base coat, or drywall surfaces prior to application of Decoplast Finishes and Coatings.*

### Coverage

800-1000 ft<sup>2</sup> (74.3-92.9 m<sup>2</sup>) per pail applied at 4 to 6 wet mils per coat

### Packaging

5 gal pail (19L) 47.5 lbs / 21.6 kg per pail

### Shelf Life

24 months, if properly sealed and stored.

### Storage

Store off the ground in a cool/dry area. Protect from extreme heat [90°F (32°C)], moisture and direct sunlight.



## Decoplast Primer

64 Standard Colors / Custom Colors

### MIXING

Mix with a clean, rust-free electric drill and paddle to a uniform consistency. Close container when not in use. Clean tools with water immediately after use.

### APPLICATION

Apply only to sound and clean, dry, properly prepared surfaces.

#### **Airless Spraying:**

Use airless sprayer with minimum 19 mil tip. Use a starting pressure of 1900 psi and adjust as necessary.

#### **As a primer:**

Apply at 4-6 wet mils per coat. Multiple coats may be required, depending on surface condition.

#### **Curing/Drying Time**

Times assume 70° F (21° C) and 50% relative humidity. Drying time varies with temperature/humidity and surface conditions. Protect installed product from rain, freezing, and continuous high humidity until completely dry.

#### **Clean Up**

Clean all tools and equipment immediately with water. Cured material may be removed by mechanical means.

### LIMITATIONS

- Use Decoplast Primer only when surface and ambient temperatures are above 40°F (4°C) and below 100°F (38°C) during application and drying period.
- Store Decoplast materials in a cool, dry place.
- Sloped surfaces: Refer to Decoplast details.
- Decoplast Primer should not be used on horizontal surfaces unless protected with appropriate Decoplast Finish materials.
- Do not apply Decoplast Primer to frozen surfaces.

### HEALTH AND SAFETY

#### **Health Precaution**

Decoplast Primer is water-based. As with any chemical construction product, exercise care when handling.

#### **WARNING!**

Causes eye and skin irritation.

#### **Safety Precaution**

Wash hands thoroughly after handling. Wear protective gloves/protective clothing/eye protection/face protection.

#### **First Aid:**

**EYE CONTACT:** Immediately flush eyes with plenty of water for at least 15 to 20 minutes. Ensure adequate flushing of the eyes by separating the eye lids with fingers. Get immediate medical attention.

**SKIN CONTACT:** Immediately wash skin with plenty of soap and water for at least 15 to 20 minutes, while removing contaminated clothing and shoes. Get medical attention if irritation develops or persists.

**INHALATION:** If inhaled, remove to fresh air. If not breathing give artificial respiration or give oxygen by trained personnel. Seek medical attention immediately.

**INGESTION:** If swallowed, do NOT induce vomiting. Call a physician or a poison control center immediately. Never give anything by mouth to an unconscious person.

#### **Spills**

Contain and clean with appropriate absorbent materials.

#### **Disposal**

Dispose of in accordance with local, state or federal regulations.

#### **Warning**

KEEP CONTAINER CLOSED WHEN NOT IN USE. KEEP OUT OF THE REACH OF CHILDREN. NOT FOR INTERNAL CONSUMPTION. FOR INDUSTRIAL USE ONLY. Consult the Safety Data Sheet (SDS) for further health and safety information.

#### **LIMITED WARRANTY**

This product is subject to a written limited warranty. Refer to Decoplast Specifications for more complete information on proper use and handling of this product.



697 Oakwood Avenue, West Hartford, CT 06110  
voice: 860.761.2830 fax: 860.761.2831  
www.decoplast.com

This product is intended for use by qualified professional contractors. All information conforms to the standard detail recommendations and specifications for the installation of Decoplast systems and is presented in good faith as of the date of publication of this document. GREENMAKER INDUSTRIES ASSUMES NO LIABILITY, EXPRESSED OR IMPLIED, AS TO THE WORKMANSHIP, ENGINEERING OR ARCHITECTURE OF ANY PROJECT. For more information regarding this product or additional Decoplast products, please contact a Decoplast Representative at (860) 761-2830 or visit our website [www.Decoplast.com](http://www.Decoplast.com).



## Decoplast Exterior Textured Finishes

Ispica (Freestyle) / Genova (Fine Sand) / San Remo (Coarse Sand)  
 Trieste (Medium Sand) / Taormina (Fine Swirl) / Graffiato (Medium Swirl)

### TECHNICAL DATA

REPORT	TEST METHOD	TEST CRITERIA	TEST RESULTS
Surface Burning	ASTM E-84	< 25 Flame Spread < 450 Smoke Developed	Pass Pass
Flexibility	ASTM D-522	4" mandrel bend	Pass
Water Vapor Transmission	ASTM E-96	28 days	Pass
Accelerated Weathering	ASTM G-154	2000 hours	Pass; No deleterious effects
Freeze-thaw Resistance	ASTM 2485	60 cycles	No deleterious effects; 90 cycles
Mildew Resistance	ASTM D-3273	No growth @ 28 days	Pass
Salt Spray Resistance	ASTM B-117	300 hours	Pass; No deleterious effects
Water Resistance	ASTM D-2247	14 days	Pass; No deleterious effects
Abrasion Resistance	ASTM D-968	528 qts. sand	No cracking, checking or Loss of film integrity @ 528 qts.
Adhesion	ASTM C-297	28 days	> 90 to concrete
Fire Resistance	ASTM E-119	No effect on fire resistance rating of Existing rated assembly	Pass; Classified UL

*Decoplast Exterior Textured Finishes are a ready-mixed, 100% acrylic based exterior textured coating used as a decorative wall finish over all approved basecoats, prepared concrete, masonry and plaster substrates.*

### Coverage

Decoplast Limestone (Ispica): Varies with technique.

Decoplast Fine Sand Finish (Genova): 130-145 ft<sup>2</sup> (12.1-13.5 m<sup>2</sup>) per pail.

Decoplast Medium Sand Finish (Trieste): 115- 130 ft<sup>2</sup> (10.7-12.1 m<sup>2</sup>) per pail.

Decoplast Coarse Sand Finish (San Remo): 85- 100 ft<sup>2</sup> (7.9-9.3 m<sup>2</sup>) per pail.

Decoplast Fine Swirl Finish (Taormina): 125-140 ft<sup>2</sup> (11.6-13 m<sup>2</sup>) per pail.

Decoplast Medium Swirl Finish (Graffiato): 130-145 ft<sup>2</sup> (12.1-13.5m<sup>2</sup>) per pail.

\*Coverages may vary depending on application technique and surface conditions

### FEATURES BENEFITS

Integral Color	Reduced recoating and maintenance; Unlimited Color Options
Weather Resistant	Repulsion of water and resistance of wind-driven rain
Breathable	Resists blistering, peeling and flaking; breathes naturally

### Packaging

5 gal pail (19L) 68.5 lbs / 31 kg per pail

### Shelf Life

24 months, if properly sealed and stored.

### Storage

Store off the ground in a cool/dry area. Protect from extreme heat [90°F (32°C)], moisture and direct sunlight.



## Decoplast Exterior Textured Finishes

Ispica (Freestyle) / Genova (Fine Sand) / San Remo (Coarse Sand)  
Trieste (Medium Sand) / Taormina (Fine Swirl) / Graffiato (Medium Swirl)

### SURFACE PREPARATION

**Concrete and masonry surfaces:** Surfaces must be clean, dry, and free of frost, damage, releasing agents, including dirt, efflorescence, form oil and other foreign matter. Loose or damaged material must be removed by water blasting, sandblasting or mechanical wire brushing and repaired. Avoid application over irregular surfaces. Resurface, patch or level surfaces to required tolerance and smoothness with appropriate Decoplast leveling materials.

#### Exterior Insulation and Finish

**Decoplast Systems (EIFS):** Surface must be free of all releasing agents.

**Gypsum wallboard surfaces:** Wallboard must be taped and fasteners spotted with joint compound. Surface must be free of dust, dirt and releasing agents. Prime with appropriate Decoplast Primer.

**Decoplast recommends priming cementitious substrates using Decoplast primer prior to application of finish.**

### MIXING

Mix with a clean, rust-free electric drill and paddle to a uniform consistency. A small amount of clean water may be added to aid workability. Limit addition of water to amount needed to achieve the finish texture. Additives are not permitted. Close container when not in use. Clean tools with water immediately after use.

### APPLICATION

Apply only to sound and clean, dry, properly prepared surfaces.

**Trowel:** Apply Decoplast Textured Finish with a clean stainless steel trowel to a rough thickness slightly more than the largest aggregate size. Apply the finish keeping thickness uniform. Maintain a wet edge on Decoplast Textured Finish by applying and texturing continually over the wall surface. Work Decoplast Textured Finish to corners, joints or other natural breaks. Do not allow material to set up within an uninterrupted wall area. Achieve final texture by floating with the appropriate trowel.

Note: Decoplast Ispica (Freestyle) Finish requires two coats.



## Decoplast Exterior Textured Finishes

Ispica (Freestyle) / Genova (Fine Sand) / San Remo (Coarse Sand)  
Trieste (Medium Sand) / Taormina (Fine Swirl) / Graffiato (Medium Swirl)

### APPLICATION Continued

**Spray:** Decoplast Textured Finishes can be applied with a gravity-feed sprayer, texture spray pump machine, or other appropriate equipment. To ensure full coverage of the surface, apply in an even coat.

IMPORTANT: ALWAYS check color for proper match.

Apply coating continuously, maintain a wet edge to eliminate cold joints. Work Decoplast Textured Finish to corners, joints or other natural breaks. Avoid application in direct sunlight. Protect installed product from rain, freezing, and continuous high humidity until completely dry.

#### Curing/Drying

Decoplast Textured Finishes dry within 24 –72 hours under normal conditions [70°F (21°C), 50% RH]. Drying time varies with temperature, humidity and surface conditions.

#### Clean Up

Clean tools and equipment with water immediately after use. Remove dried material from tools and equipment mechanically.

### LIMITATIONS

Use Decoplast Textured Finishes only when surface and ambient temperatures are above 40°F (4°C) and below 100°F (38°C) during application and drying period.

Store Decoplast materials in a cool, dry place.

Sloped surfaces: Refer to Decoplast details.

Decoplast Textured Finishes should not be used on weather-exposed horizontal or below grade surfaces or where immersion in water may occur.

Do not apply Decoplast Textured Finish to frozen surfaces.

### HEALTH AND SAFETY

#### Health Precaution

Decoplast Textured Finishes are water-based. As with any chemical construction product, exercise care when handling.

#### WARNING!

Causes eye and skin irritation.

#### Safety Precaution

Wash hands thoroughly after handling. Wear protective gloves/protective clothing/eye protection/face protection.

#### First Aid:

**EYE CONTACT:** Immediately flush eyes with plenty of water for at least 15 to 20 minutes. Ensure adequate flushing of the eyes by separating the eye lids with fingers. Get immediate medical attention.

**SKIN CONTACT:** Immediately wash skin with plenty of soap and water for at least 15 to 20 minutes, while removing contaminated clothing and shoes. Get medical attention if irritation develops or persists.

**INHALATION:** If inhaled, remove to fresh air. If not breathing give artificial respiration or give oxygen by trained personnel. Seek medical attention immediately.

**INGESTION:** If swallowed, do NOT induce vomiting. Call a physician or a poison control center immediately. Never give anything by mouth to an unconscious person.

#### Spills

Contain and clean with appropriate absorbent materials.

#### Disposal

Dispose of in accordance with local, state or federal regulations.

#### Warning

KEEP CONTAINER CLOSED WHEN NOT IN USE. KEEP OUT OF THE REACH OF CHILDREN. NOT FOR INTERNAL CONSUMPTION. FOR INDUSTRIAL USE ONLY. Consult the Safety Data Sheet (SDS) for further health and safety information.

#### LIMITED WARRANTY

This product is subject to a written limited warranty. Refer to Decoplast Specifications for more complete information on proper use and handling of this product.

-5- YEAR\_ LIMITED WARRANTY

Disclaimers and Limitations of Remedies

"Material"



---

Greenmaker Industries warrants to the below Owner that for the - 5 - year Warranty Period stated above and subject to the exceptions listed below, the " \_\_\_\_\_ " (the "system") described above, as properly applied by the Registered Applicator, will maintain its bond, be water resistant and will not peel, flake or chip. For any valid claim presented under this Warranty, Greenmaker Industries will supply Owner with replacement materials and labor required to Repair any non-conforming portions of the installed System. Any replacement materials provided hereunder will also be subjected to all the provisions of the Warranty during the Warranty Period shown above.

WARRANTIES DISCLAIMED – THE WARRANTY STATED IN THE PARAGRAPH ABOVE IS IN PLACE OF ALL OTHER WARRANTIES, EXPRESSED OR IMPLIED. GREENMAKER INDUSTRIES EXPRESSLY DISCLAIMS ANY OTHER WARRANTIES INCLUDING WARRANTIES OF MERCHANTABILITY AND FITNESS FOR A PARTICULAR PURPOSE. ALTHOUGH GREENMAKER INDUSTRIES MAY HAVE SUGGESTED THE MATERIAL OR DEVELOPED THE MATERIAL AT THE REQUEST OF THE GC, OWNER OR OWNERS REP, IT IS THE RESPONSIBILITY OF THE MANUFACTURER TO TEST AND DETERMINE THE SUITABILITY OF THE MATERIAL FOR THE INTENDED USE AND PURPOSE, AND THE APPLICATOR ASSUMES ALL RISK AND LIABILITY WHATSOEVER REGARDING SUCH SUITABILITY IF NOT INSTALLED AS PER MANUFACTURER SPECIFICATIONS.

LIMITATIONS OF REMEDIES AND DAMAGES – THE REPLACEMENT/REFUND REMEDY STATED IN THIS WARRANTY TAKES THE PLACE OF ALL OTHER REMEDIES AGAINST GREENMAKER INDUSTRIES AND IS THE ONLY REMEDY AGAINST DECOPLAST SYSTEMS, INC. AVAILABLE TO OWNER OR TO ANY OTHER PARTY, IN NO EVENT WILL GREENMAKER INDUSTRIES BE LIABLE FOR SPECIAL, INDIRECT, INCIDENTAL OR CONSEQUENTIAL DAMAGES (INCLUDING LOST PROFITS) ARISING OUT OF OR CONNECTED TO THE MATERIALS OR THE SYSTEM, OR TO ANY USE OR MISUSE OF THE MATERIALS OR THE SYSTEM, REGARDLESS OF ANY STRICT LIABILITY OR ACTIVE OR PASSIVE NEGLIGENCE OF GREENMAKER INDUSTRIES AND REGARDLESS OF THE LEGAL THEORY (CONTRACT, TORT OR OTHER) USED TO MAKE A CLAIM, IN NO EVENT WILL GREENMAKER INDUSTRIES BE OBLIGATED TO PAY DAMAGES IN ANY AMOUNT EXCEEDING THE ORIGINAL PRICE OF THE MATERIALS SHOWN TO BE DEFECTIVE. For customer relations purposes, Greenmaker industries may in its sole discretion choose to make some

efforts beyond its legal obligations. Such additional efforts will not in any way change the limitations of remedies and damages stated in this paragraph or extend or change this Warranty.

Exclusions: The warranty described above does not cover, and Greenmaker Industries will have no liability for any damage or failure of the System caused by or due to any of the following:



1. Lightning, earthquake, windstorm, hurricane, tornado, hail, fire, flood or other unusual phenomena of the elements or acts of nature.
2. Settlement, movement, deflection, warpage, distortion, displacement or any other failure of the substrate. Such failures are the sole responsibility of the substrate manufacturer.
3. Cracks, breaks or openings in the substrate to which the System is applied.
4. Surface alterations, additions, object placed or installations made on the finished surface.
5. Use of the finished surface as something other than an exterior wall (such as a recreational area or walking surface).
6. Penetration, vandalism, damage or attack by third parties and foreign objects or agents, including but not limited to chemicals, animals and plant life.
7. Discoloration or change in visual appearance due to accumulation or streaking of dirt or other airborne materials deposited on the surface from the atmosphere.
8. Sealant failure or water penetration due to leaks through windows, air conditioning units, holes, louvers, vents, or other non-System elements made part of a System installation.
9. Other (explain):

Furthermore, the warranty described above does not cover, and Greenmaker Industries will have no liability for, any repairs to the System or repaired portions of the System, except as set forth in the sections covering Repairs and Emergency Repairs, below.

**Warranty Claims.** Owner shall notify Greenmaker Industries immediately of any alleged defect in the materials covered by this Warranty. Owner will provide Greenmaker Industries with a reasonable opportunity to review and investigate the alleged defect. For any valid claim presented under the Warranty, Greenmaker Industries will provide the Owner with a remedy as described above. For any claim that is not valid, Owner will pay Greenmaker Industries reasonable charges, including travel and labor, associated with investigation of such claim.

**Repairs.** Any portions of the System either repaired by Greenmaker Industries or repaired by Applicator and approved in writing by Greenmaker industries will be subject to the terms of this Warranty for the remainder of the Warranty Period.

**Emergency Repairs.** If immediate and material damage to the building and its contents is imminent due to an alleged failure of the System, the Owner may, at its own expense, make such temporary repairs as may reasonable be required to prevent such damage. If Greenmaker Industries thereafter determines that the temporary repairs were necessitated by a failure of the System, Greenmaker Industries will provide a remedy as described above. If Greenmaker Industries determines that such emergency repairs were made in accordance with Greenmaker Industries standards, such repaired

portions will be subject to the terms of this Warranty for the remainder of the Warranty Period. If Greenmaker Industries determines that the temporary repairs were either not necessitated by a failure

of the System, or were not made in accordance with Greenmaker Industries standards, the warranty described in this Warranty will be null and void with respect to the repaired portions of the System. In no case will



Greenmaker Industries be held responsible for any damages done to the System by others in performing any repairs.

Voidability. The limited warranty contained herein will become null and void upon notice by Greenmaker Industries if:

1. Owner fails to provide prompt notification of any alleged defect in the System.
2. Owner denies Greenmaker Industries a reasonable opportunity to review and investigate an alleged failure of the System; or
3. Owner fails to pay when due the full contract price for the System and any other charges owing to Greenmaker Industries under the terms of this Warranty; provided, however, that all other terms of this limited warranty, including warranty disclaimers and limitations of remedies and damages, will remain in full force and effect despite such a nullification.

Assignability. The transfer of this Warranty to a new owner may be made only if acknowledged in writing by Greenmaker Industries to the new owner. Greenmaker Industries must be notified at the time of sale to the new owner, and Greenmaker Industries must be satisfied that the intended use of the structure by the new owner will not cause detriment to the System.

Validation. This Warranty is void unless signed by authorized representatives of Greenmaker Industries

Complete Agreement. This Warranty completely replaces and supersedes any prior oral or written warranties agreements or representations relative to the System, The System material or the application of such materials. No one other than an officer or general manager of Greenmaker Industries is authorized to change this Warranty or any of its provisions.

Owner: \_\_\_\_\_  
\_\_\_\_\_  
\_\_\_\_\_

Location: \_\_\_\_\_

Certified Applicator: \_\_\_\_\_

General Contractor: \_\_\_\_\_

Company Issuing Warranty: **Greenmaker Industries**

Project Size: \_\_\_\_\_ SFT System Installed: \_\_\_\_\_

Date Product Purchased: \_\_\_/\_\_\_/\_\_\_ thru: \_\_\_/\_\_\_/\_\_\_

Warranty Expiration Date: \_\_\_/\_\_\_/\_\_\_

Signature & Title: *Michael Jalbert* Technical Director Date: \_\_\_/\_\_\_/\_\_\_



697 Oakwood Avenue, West Hartford, CT 06110  
voice: 860.761.2830 fax: 860.761.2831  
www.decoplast.com