

WEATHER-RESISTIVE BARRIER

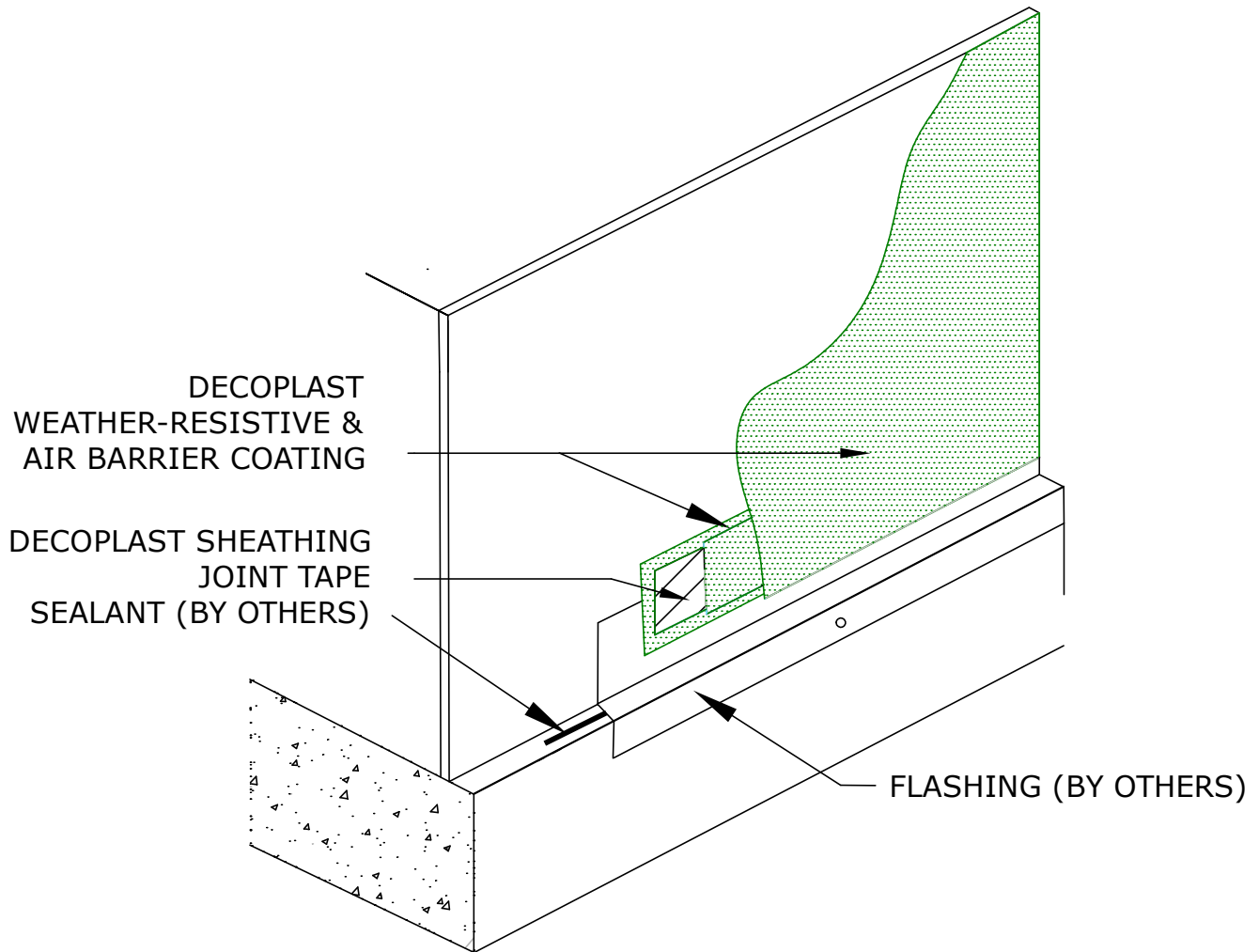

DLWB 1.06 TERMINATION AT FOUNDATION FLASHING

DECOPLAST WEATHER-RESISTIVE BARRIER - 6/1/2016

Notes:

To ensure a continuous air barrier across the building envelope, a continuous air seal should be made at each substrate change, joints/gaps, penetrations and dissimilar material terminations. There must be a consideration of the Designer in the overall wall assembly design. Stucco claddings and any cladding using a mortar bed require the use of a slipsheet installed over the Water-Resistive & Air Barrier Coating to prevent adhesion to the stucco.

Disclaimer: The design, specifications, and construction shall comply with all local building codes and standards. Decoplast installation guidelines are for general information and guidance only and Decoplast specifically disclaims any liability for the use of this design, and for design, engineering, or workmanship of any project. The assembly shall be designed to prevent condensation within the assembly. The designer and the user shall provide final drawings and specifications. Products shown other than those manufactured by Decoplast are shown for clarity of the Decoplast product only. Contact the manufacturer of such other products for installation instructions.